

Drought Management Plan



Tooloom Creek Falls



Tenterfield Dam

Document Control

Version	Date	Modified by	Approved by	Details
V1.0	10/08/2020	Melissa Blum	Gillian Marchant	Original

This plan was adopted by Council on 25th August 2020 - Resolution Number 162/20

Contents

1	Introduction	7
1.1	Context	7
1.2	This Plan.....	7
1.3	Drought Planning	8
1.3.1	Objectives of Drought Planning	8
1.3.2	The PRR Approach	8
1.3.3	Mental Health and Drought.....	9
2	Drought Prevention Strategy	10
2.1	Overview	10
2.2	Short Term Actions	10
2.2.1	Voluntary Water Restrictions.....	10
2.2.2	System Improvements.....	10
2.2.3	Drought Water Pricing.....	11
2.3	Long-term Actions.....	12
2.3.1	Off-stream Storage - Urbenville	12
2.3.2	Mole River Dam.....	12
3	Drought Preparedness	13
3.1	Overview	13
3.2	Exercising Drought Management.....	13
3.3	Data Availability.....	14
3.4	Monitoring	14
3.5	Consultation.....	14
3.5.1	Community Engagement	14
3.5.2	Government Consultation	15
3.5.3	Customers.....	15
3.6	Making Council Water Wise	17

4	Drought Response Strategy	18
4.1	Drought Strategy Activation Plan	18
4.1.1	Overview.....	18
4.1.2	Drought Triggers	18
4.2	Drought Management Team Roles and Responsibilities	20
4.2.1	Activation and Setting Restriction Levels	20
4.2.2	Drought Management Team.....	20
4.3	Demand-Side Action Plan.....	22
4.3.1	Water Restrictions	22
4.3.2	Demand Targets.....	22
4.3.3	Demand Side Activities	24
4.4	Supply-Side Action Plan	27
4.4.1	Staged Action-Plan	27
4.4.2	Water Carting	28
4.5	Monitoring During Drought.....	29
4.6	Communications Strategy	30
4.6.1	Community.....	30
4.6.2	Agencies	35
5	Drought Recovery Strategy	38
6	Tenterfield Water Supply Scheme	40
6.1	Existing Water Supply Scheme	40
6.2	Water Sources.....	44
6.2.1	Existing Sources.....	44
6.2.2	Potential Sources	50
7	Urbenville, Muli Muli, Woodenbong Water Supply Scheme	52
7.1	Existing Water Supply Scheme	52
7.2	Water Sources.....	54
7.2.1	Existing Sources.....	54

7.2.2	Potential Sources	57
8	Jennings Water Supply Scheme	58
8.1	Existing Water Supply Scheme	58
8.2	Water Sources.....	59
8.2.1	Existing Sources.....	59
8.2.2	Potential Sources	59
9	Water Demand	59
9.1	Water Pricing.....	59
9.2	Water Users	60
9.3	Water Usage	61
9.3.1	Tenterfield.....	61
9.3.2	Urbenville.....	64
9.3.3	Jennings.....	66
9.4	Top Water Consumers	66
10	Climate.....	67
10.1	Rainfall, Evaporation and Temperature	67
10.1.1	Tenterfield	67
10.1.2	Urbenville	68
10.1.3	Jennings.....	71
10.2	Drought Restrictions History	72
10.3	Effects of Restrictions on Water Demand.....	76
10.4	Supply-Side Historical Actions.....	78
10.4.1	Tenterfield	78
10.4.2	Urbenville	78
11	Regulatory Framework.....	79
11.1	Local Water Utility	79
11.2	DPIE Water	79
11.2.1	General	79

11.2.2	Water Sharing Plans.....	80
11.3	Fire Fighting Requirements.....	80
Appendix A.	SDRC Water Restrictions	81
Appendix B.	Water Exemption Application Form	84
Appendix C.	Water Carters Registration Form	87
Appendix D.	Waterwise Checklist.....	89
Appendix E.	Example Water Restrictions Poster	92
Appendix F.	Tenterfield Water Supply and Restriction Levels	95

List of Tables

Table 3-1	Critical Customers and their water use.....	16
Table 3-2	Council Water Wise Action Plan	17
Table 4-1	Proposed Water Restrictions Triggers	19
Table 4-2	DMT Roles and Preliminary Responsibilities.....	21
Table 4-3	Water Restrictions Table.....	25
Table 4-4	Staged Drought Supply-Side Actions.....	28
Table 4-5	Local Media Contact List	33
Table 4-6	Local Community Groups Contact List	34
Table 4-7	Regional Media Contact List	35
Table 4-8	Agencies Contact List.....	35
Table 9-1	Water Demand for the Shire Townships.....	60
Table 10-1	Tenterfield Drought restrictions history.....	73
Table 10-2	Urbenville Drought restrictions history.....	74
Table 10-3	Jennings Drought restrictions history	75
Table 11-1	SDRC Water Use Targets	81
Table 11-2	SDRC Water Restrictions - High.....	81
Table 11-3	SDRC Conditional Use: Water Restrictions - Residential	82
Table 11-4	SDRC Conditional Use: Water Restrictions - Commercial.....	83
Table 11-5	SDRC Conditional Use: Water Restrictions - Community	83

List of Figures

Figure 6-1	Tenterfield Creek Dam	41
Figure 6-2	Water Depth-Storage Curve for Tenterfield Dam.....	41
Figure 6-3	Tenterfield Bore Network	42
Figure 6-4	Tenterfield Water Supply Schematic (Viridis, 2018).....	43
Figure 6-5	Average Consumption Vs Dam Level 2018 Drought.....	46
Figure 6-6	Average Monthly Rainfall Vs Dam Capacity 2018 Drought	47
Figure 6-7	Bulk water purchases during drought period	48
Figure 6-8	Consumption of non-potable water from Apex Park during drought period	49
Figure 7-1	Tooloom Creek intake – UMMWWS Scheme	52
Figure 7-2	Urbenville Water Supply Schematic (Viridis, 2018).....	53
Figure 7-3	Average Consumption Vs Weir Level 2018 Drought.....	55
Figure 7-4	Average Monthly Rainfall Vs Weir Capacity 2018 Drought	56
Figure 8-1	Jennings Water Supply Schematic (Viridis, 2018)	58
Figure 9-1	Contribution to Water Demand 2018/2019.....	61
Figure 9-2	Long Term Consumption and Dam Levels for Tenterfield.....	63
Figure 9-3	Long Term Consumption and Creek Levels for Urbenville	65
Figure 9-4	Long Term Consumption for Jennings.....	66
Figure 9-5	Top water users	67
Figure 10-1	Tenterfield Climate Data	68
Figure 10-2	Urbenville Rainfall Data	69
Figure 10-3	Warwick Climate Data	70
Figure 10-4	Urbenville Climate Data	70
Figure 10-5	Wallangarra Rainfall Data	71
Figure 10-6	Stanthorpe Climate Data	72
Figure 10-7	Tenterfield’s response to water restrictions 2002-2004.....	77

1 Introduction

1.1 Context

This Drought Management Plan (DMP) has been developed in order to:

- Provide guidance to staff when managing drought events;
- Inform the community of the issues associated with drought management and the community's role during drought.

The NSW Government Best-Practise Management of Water Supply and Sewerage Guidelines (2007) require Local Water Utilities (LWU) to have a sound DMP in place and be ready to implement their plan when drought conditions arise. This plan satisfies the guideline requirement. This plan has been developed utilising the Water Directorate Drought Management Planning Guidelines (2016).

1.2 This Plan

This DMP provides a combination of long-term and short-term management actions to respond to drought incidents and nominates who is responsible for acting upon these situations. The aims of this plan are to:

- Ensure that timely warning can be provided to the appropriate authorities and other stakeholders (including customers) in a drought event;
- Provide relevant information for use in response to a situation when water availability becomes a concern;
- Identity customer groups who have different requirements during droughts, for example, hospitals and schools;
- Outline procedures to Council staff so as to respond to and mitigate drought related issues;
- Enable timely warning to appropriate personnel to implement appropriate actions;
- Document how Tenterfield Shire Council (Council) will manage the water supply scheme during water shortages due to drought.

The plan has several uses:

- As an operational plan for water supply management during drought;

- As a resourcing and staff allocation strategy to manage drought;
- As an authorised approach to drought management enabling staff to act knowing that necessary actions have been endorsed beforehand;
- As the basis for government grant applications to address the needs identified in this plan;
- As the basis of a public awareness and community communication tool for use by Council to demonstrate transparent and responsible drought managements.

This plan includes strategies specific to the Tenterfield Shire Council water supplies at Tenterfield and Urbenville and information about the Southern Downs Regional Council water supply that services Jennings. Consideration is also given to villages in the Shire who currently have no access to Council water infrastructure.

1.3 Drought Planning

1.3.1 Objectives of Drought Planning

Drought planning is an emergency response plan that aims to reduce the impact of water scarcity on the community, business, economy and environment.

1.3.2 The PPRR Approach

This plan is based on a four-step approach referred to as PPRR (prevention, preparation, response and recover) approach. The PPRR is a continuous process that involves effectively integrating implementation strategies before (i.e. prevent and prepare), during and after drought events with particular emphasis on response and recovery.

An overview of the four phases is provided below:

- **Prevention** Actions to reduce or eliminate the likelihood or effects of drought related issues. These include understanding the climate patterns and their impact on water availability, understanding water sharing plan rules and analysing past drought events. They may also include upgrading the water resources, typically through capital investment.

- **Preparedness** Developing strategies for drought situations before and incident occurs, to ensure effective response and recovery. This DMP is a key component of this phase.
- **Response** Actions to control, contain and/or minimise the impacts of the drought. Typically this would involve implementation of demand-side and supply-side actions listed in this DMP.
- **Recovery** Restoration of 'normal' water supply conditions, including actions to assist the community and businesses to recover from the impacts of drought.

This plan describes the actions that Council will implement in the prevention, preparation, response and recovery stages of a drought incident.

1.3.3 Mental Health and Drought

Drought causes significant mental health issues in communities. These issues are caused by, but not limited to:

- loss of control,
- being unsure if they have enough water,
- continually minimising water use,
- being unsure if they will have jobs or are able to maintain their livelihood,

Adequate communication about the current state of Council water resources and the drought management plan can go some way to alleviating the stresses around drought for those in towns. Council can assist rural villages minimise water stresses by assisting in finding/investigating viable alternative water supply solutions.

Mental health is a consideration in the escalation of the water restrictions, and in what is allowed in each restriction level.

2 Drought Prevention Strategy

Note: the term 'drought prevention' may appear inappropriate, as a drought is caused by external forces. However, for a water utility, a drought is a water shortage and therefore it may be prevented or delayed.

2.1 Overview

Drought prevention actions are proactive measures that LWU's can undertake in order to increase coping capacity. Prevention actions may be activated / implemented prior to drought or during drought-declared periods. This will be determined at Council's discretion.

During drought, existing water resources are expected to decrease at a rate dependent on the respective water demand rate at a particular water restriction level. While current water resources are diminishing, other supply options may be considered as potential alternatives for supplementary or emergency water sources.

Some prevention actions are described below.

2.2 Short Term Actions

2.2.1 Voluntary Water Restrictions

When the water source's availability is approaching the level that would trigger the implementation of water restrictions. Council will start a pre-activation of voluntary water restrictions (i.e. implementation of water conservation measures).

Council will use the media to communicate the importance of using water saving measures, especially in times approaching drought. Further information on restrictions can be found in Section 4.

2.2.2 System Improvements

Council has identified the following improvements to the water supply system. These are being programmed into the maintenance / renewal programs. The improvements include:

Tenterfield:

- Survey of the Tenterfield Dam. A bathymetric survey of the dam will occur periodically, and particularly after major flood events.
- Tenterfield Dam improvements. The program will be developed depending on the outcome of the survey.
 - Desilting of the edge of the dam will be undertaken if required and when possible during a drought.
 - Dredging may be possible in non-drought conditions.
- Bore optimisation. Monitor the use and performance of the bores installed in 2019 and modify operations to optimise the use as required.

Urbenville

- Survey the intake. A bathymetric survey of the inlet will occur periodically, and particularly after major flood events. This will allow Council to decide the volume that is required to be desilted
- Desilting of the inlet. The program will be developed depending on the outcome of the survey.

Jennings

- Council will work with Southern Downs Regional Council to determine actions that can be undertaken to improve the Wallangarra water supply system.

Other Villages

- Investigation into emergency water sources. Examples could include tanks, bores and small dams. The cost of providing treatment of this water to potable standard is likely to be cost prohibitive – consultation will be required with these communities to outline potential costs of a potable supply to determine their willingness to pay. Otherwise, non-potable water can be supplied for a user-pays fee. This water would also be available for fire-fighting purposes.

2.2.3 Drought Water Pricing

For future droughts, it is proposed to increase the water price (\$/KL) when the Tenterfield dam drops to 60%. Once the water level in the dam exceeds 60%,

then the water price will return to the original price. This will act as both a price signal that the communities need to save water and ensure that the water supply will achieve full cost recovery. *Note: a determination as to what the increase in water price might be will be made after December 2020, when the water consumption figures for the half-yearly water reads are available.*

2.3 Long-term Actions

The Integrated Water Cycle Management Plan (IWCMP) is due to be updated in 2021. The update of the IWCMP may have implications for this plan. The DMP should be reviewed once the update is complete.

2.3.1 Off-stream Storage - Urbenville

There is potential to create an off-stream storage area for Urbenville. Investigations are currently underway into this option, with a proposed storage capacity of between 50-160ML located close to the Urbenville WTP.

Off-stream storage will increase the water security of Urbenville and provide an additional step in the water treatment process. It will allow the creek

This project will be dependent on being granted funding.

2.3.2 Mole River Dam

The Mole River Dam is a joint project to create a new dam in the Boarders Rivers catchment. The dam is proposed to have a storage capacity of 100GL, which can be accessed by the local agricultural sector for irrigation and Local Councils for water supply. The project is currently at the Development & Approvals stage (2020). The project is estimated to take 6-8 years until the dam is operational (i.e. in 2026-2028).

There is potential for Council to secure a water allocation to service our towns. Council will continue to lobby the Government to secure a water allocation for this dam.

3 Drought Preparedness

3.1 Overview

Being prepared for a drought is essential to lessen the effect and to enhance the capacity of Council and the community to cope with the consequences of drought. This means that Council should have action plans in place ready to be implemented and have ongoing activities to prepare Council staff and the community for those situations, such as training exercises, monitoring and consultation.

The major benefits of being prepared for incidents or having a sound drought management plan are:

- Having a pre-determined and agreed list of actions to be taken care of in case of drought situations, allowing for an effective implementation of those actions.
- Allows Council to promptly obtain drought relief funds from relevant authorities;
- Have well defined protocols of drought restriction activation and escalation.

This DMP documents Council's preparedness in regards to incidents affection town water supply. The actions described in this plan have been endorsed by Council, therefore in case of emergencies, the appointed staff can quickly activate relevant personnel required to take actions to respond to the problem, to acquire other resources required for drought management and to quickly implement the pre-determined drought response actions outlined in Section 4. The following sections describe some of the ongoing activities that Council should undertake in order to be prepared for drought situations.

3.2 Exercising Drought Management

In order to ensure the ongoing effectiveness of this plan and to prepare staff for emergency situation, a periodic program for exercising drought management will be developed and implemented in conjunction with other emergency training

programs. These exercises will be a simulation of drought starting and intensifying, and initiating the corresponding actions.

3.3 Data Availability

The DMP included, as attachments, technical information (i.e. design, operational, maintenance plans) relevant to the water supply system. This is to ensure that in case of emergencies all relevant information is in one document facilitating an effective and prompt response to the problem.

These attachments should be updated regularly, as the plans are modified.

3.4 Monitoring

Continuous monitoring of the water sources and water supply schemes is essential to understand the performance of the water sources and their capacity of supplying demand. Monitoring of these parameters assists Council in preparing for unconventional situations. In order to ensure a safe and sustainable water supply, the following monitoring is required. Council will review the current monitoring stations and confirm if there is a need to upgrade any existing or install new stations, depending on grant funding.

- Drinking water daily demand
- Daily monitoring of water supply sources:
 - Water level at dams (Tenterfield & Jennings);
 - River flows and depths (Urbenville);
 - Water level at bores (Tenterfield).
- Daily temperature and rainfall.

3.5 Consultation

3.5.1 Community Engagement

Engagement with the community is a critical element of an effective drought management program, as it ensures customer acceptance and behavioural changes, required to reduce water demand.

Council will inform the community about the DMP and the drought action plans in place. This will assist the community to understand the critical importance of drought management actions and the need to conserve water.

Council has involved the community in the development and review of this plan.

3.5.2 Government Consultation

Consultation on the implementation of the Drought Management Plan would be expected to be with:

- Department of Planning, Industry & Environment
- NSW Health (especially in terms of water quality)
- Neighbouring Councils

3.5.3 Customers

There are a number of critical water users throughout the Shire, including hospitals, aged care facilities and schools. These customers are listed in Table 3-1. It is important for Council to understand the critical customers and their water requirements to ensure that there is sufficient water to enable them to provide. Council can also work with these customers, and other high water users, to complete a water audit to discover how they are using their water and if there are ways to save water or if there are alternative water sources that may be feasible. There are also some private residences that *may* require additional water, for example, those on dialysis. People in this position have not been listed in this document to preserve privacy.

It is important to understand the requirements of fire fighters, as they provide a critical service to the community. It is imperative that Council work with the local Fire and Rescue and RFS to ensure that there is provision made to ensure that there is water available on demand. Fire and Rescue rely on the reticulated water system (using hydrants), whereas RFS rely more on non-reticulated sources, such as creeks and farm dams. In certain circumstances they may also draw directly from Council's water supply dam. For more information on this, please see Section 11.3.

Table 3-1 Critical Customers and their water use

Customer	Description (maximum numbers)	Typical water use (KL) / year¹
Critical Customers - Tenterfield		
Tenterfield Hospital	14 hospital beds and 24 staff	948
Haddington Nursing Home	46 residents and 118 staff (combined with Millrace)	5,112
Millrace Hostel	35 residents and 118 staff (combined with Millrace)	3,425
Tenterfield Preschool	29 children and 6 staff	158
Tenterfield Childcare Centre	39 students and 12 staff	316
Sir Henry Parkes Memorial Primary School		588
St Joseph Primary School	124 students and 19 staff	337
Tenterfield High School	244 students and 45 staff	777
TAFE	20 students and 5 staff	415
Tenterfield Fire and Rescue	Typically have 90 calls per year requiring water use. Average water use per callout is 3,000L.	270 ²
Tenterfield RFS		
Critical Customers - Urbenville		
Urbenville Hospital		1,747
Urbenville Public School	10 students and 5 staff	99
Urbenville RFS		
Woodenbong Central School	180 students and 45 staff	2,739
Woodenbong RFS		
Critical Customers - Jennings		
Jennings Public School	19 students and 5 staff	86
¹ This is based on the average usage from 2017-2020		
² Note, in 2019, there were 198 call outs, resulting in a water usage of 594KL		

3.6 Making Council Water Wise

In order for Council to be a leader in drought management, we need to ensure that we are leading by example. Table 3-2 following table outlines actions Council will be undertaking, including timeframes and responsible department.

Table 3-2 Council Water Wise Action Plan

Action	Description	Timeframe	Responsible Department
Water Audit	Undertake a water audit of key Council buildings to inform further actions	Within 2 years	Water & Waste
Water efficient gardens	Upgrade Council watering system to a water efficient system	As systems get replaced/updated	Open Space, Regulatory & Utilities
	Ensure systems with timers are programmed not to water during 9am to 4pm.	Within 6 months	
Water Tanks	Ensure all Council buildings (where feasible) have water tanks that are appropriately plumbed	As upgrades occur	Property / Buildings
Water efficient devices	Ensure that as appliances are upgraded that they are replaced with water efficient devices	As upgrades occur	Property / Buildings

4 Drought Response Strategy

The response strategy consists of implementing appropriate actions to control, contain or minimise the impacts of droughts. The implementation of the DMP including identifying and reviewing situations, overseeing the implementation of supply and demand actions, approving media releases and reviewing operations will be the responsibility of the Drought Management Team.

The following sections describe the response strategy during drought incidents.

4.1 Drought Strategy Activation Plan

4.1.1 Overview

The drought response strategy will be activated in an event when the water supply is affected due to natural climate conditions.

The main scenario that would activate a drought management response, including the introduction of supply restrictions, is water scarcity. Scarcity is defined in Table 4-1.

4.1.2 Drought Triggers

Triggers are situation that will activate the response strategy plan. The triggers are based on progressive reductions in water availability. The triggers from implementing drought restrictions are provided in Table 4-1.

These triggers initiate demand-side actions which are expected to reduce the demand to a target daily demand (refer to Table 4-3). If the demand reduction is not achieved by the introductions of the restrictions for each level, the next level should be applied.

Table 4-1 lists water supply system drought trigger levels. The Relax column indicates the mark where the level can be relaxed and the status changed to a lower level.

Table 4-1 Proposed Water Restrictions Triggers

Level	Trigger		Relax	
	Storage Condition	Other	Storage Condition	Other
Permanent water conservation	>70% Dam: <1m below spillway Weir: <0.45m below weir	<ul style="list-style-type: none"> Seasonal conditions (hot, cold, holiday periods) Climatic trend (e.g. low rainfall over a period) 	N/A	
Level 1 Low	70% Dam: 1.0m below spillway Weir: 0.45m below weir	<ul style="list-style-type: none"> Authoritative advice on an adverse climatic forecast Critical loss of pumping capacity Water source deterioration in capacity. The supply will last 9 months. Reduction in water allocation by regulatory authority. 	75% Dam: 0.76m below spillway Weir: 0.8m below weir	<ul style="list-style-type: none"> Supply is not restricted Storage is 12 months or more
Level 2 Moderate	60% Dam: 1.3m below spillway Weir: 0.6m below weir	<ul style="list-style-type: none"> System failure affecting the ability to supply. Demand exceeding capacity of the system to supply. Water source deterioration in capacity. The supply will last 6 months. Rainwater dependent communities without water. Consumption target of previous level not achieved for 1 week. 	65% Dam: 1.1m below spillway Weir: 0.52 below weir	<ul style="list-style-type: none"> System is operational. Storage is 9 months or more
Level 3 High	50% Dam: 1.7m below spillway Weir: 0.75m below weir	<ul style="list-style-type: none"> Widespread contamination of water source or supply. Water source deterioration in capacity. The supply will last 5 months. Consumption target of previous level not achieved for 1 week. 	55% Dam: 1.5m below spillway Weir: 0.67m below weir	<ul style="list-style-type: none"> Source water is within WWTP raw water parameters Storage is 6 months or more
Level 4 Very High	40% Dam: 2.2m below spillway Weir: 0.9m below weir	<ul style="list-style-type: none"> Water source deterioration in capacity. The supply will last 3 months. Consumption target of previous level not achieved for 1 week. 	45% Dam: 1.9m below spillway Weir: 0.82m below weir	<ul style="list-style-type: none"> Source water is back to normal Storage is 5 months or more
Level 5 Emergency	15% Dam: 3.9m below spillway Weir: 1.25m below weir	<ul style="list-style-type: none"> Water source deterioration in capacity. The supply will last 2 months. Consumption target of previous level not achieved for 1 week. 	35% Dam: 2.3m below spillway Weir: 0.97m below weir	Storage is 3 months or more

4.2 Drought Management Team Roles and Responsibilities

4.2.1 Activation and Setting Restriction Levels

Council's Chief Executive (CE) in consultation with the Mayor, can proclaim this drought management plan to be in force once the CE determines that Trigger has been reached.

The Chief Executive with the Mayor have the authority to change the restriction levels on the advice from the Drought Management Team.

4.2.2 Drought Management Team

The CE will appoint the drought management team (DMT). The roles and responsibilities are outlined in Table 4-2.

Table 4-2 DMT Roles and Preliminary Responsibilities

Role	Position in Council	Responsibilities
Chair	Levels 1-2: Water & Waste Manager Level 3-4: Director Infrastructure Level 5: Chief Executive	<ul style="list-style-type: none"> • Coordinate the activities of the team • Communication with Council • Communicate with Government agencies – high level • Provide media interviews, if required
Incident Manager	Level 1-2: Projects Engineer (Water) Levels 3 and above: Water & Waste Manager	<ul style="list-style-type: none"> • Monitor and assess data • Provide an assessment of the situation. • Brief the DMT Chair and Council • Allocated roles to team members, including stand-ins • Prioritise tasks and develop response actions • Ensure adequate facilities and resources – both specialist and support • Communicate with stakeholders, neighbouring LWUs, Government agencies and major customers – action level • Hold regular team meetings • Monitor the use of actions and their effectiveness • Monitor team member performance and action if required • Determine completion of the response phase and commence recovery • Post include – coordinate review of incident and update DMP
Communication Manager	All levels: Incident Manager	<ul style="list-style-type: none"> • Support the DMT Chair with communication • Prepare communication material as appropriate • Issue media statements • Maintain media databased including social networks
Administrative Support	Water & Waste Admin	<ul style="list-style-type: none"> • Record keeping • Prepare progress reports as required for distribution to DMT members • Provide administrative support, answer telephones, email first review and general office duties • Attend and minute meetings

4.3 Demand-Side Action Plan

4.3.1 Water Restrictions

Water restrictions aim to reduce water demand by customers through regulating the type and duration of water-using activities. If not specifically mentioned otherwise, the restrictions of each level apply to all the higher levels. For example, if fixed hoses are prohibited for Level 2, fixed hoses are also prohibited for all the higher levels.

The restrictions are shown in Table 4-3 and apply to any consumer accessing Tenterfield Shire Council's potable water supply.

It should be noted that Jennings sources their water from Southern Downs Regional Council (SDRC), and restrictions from SDRC will apply to this township. Refer to Appendix A for details.

Appendix B provides the water exemption form and Appendix C provides the water carters registration form.

4.3.2 Demand Targets

Level 1 (Low)

This restriction strategy will aim to reduce normal average daily household consumption by 10% to a target level of 280L per person per day (L/P/d).

Businesses are not being strongly targeted at this level, but are encouraged to reduce consumption.

Level 2 (Moderate)

The second level of restrictions will aim to reduce normal average daily household consumption by 10-20% to a level of 280-250L per person per day. An increase in the advertising campaign for a reduction in water usage will be implemented.

Businesses are encouraged to review their water consumption and use tools such as the Water wise checklist to identify areas where they may be able to save water. The checklist can be found in Appendix D.

Level 3 (High)

The third level of restrictions will aim to reduce normal average daily household consumption by 20-30% to a level of 250-220L per person per day.

During this stage, policing is implemented with the increased monitoring of water usage throughout the community. Households and businesses with excess consumption levels will receive warning letters informing them of the possible fines that may be incurred if consumption within the dwelling or business is not decreased. During this stage, alternate water sources, such as the Tenterfield bore field, will be investigated and plans for implementation developed.

Businesses are encouraged to try to reduce water use. They are encouraged to discuss with Council if they are having issues reducing water consumption.

Level 4 (Severe)

The fourth level of restrictions will aim to reduce normal average daily household consumption by 30-40% to a level of 220-190L per person per day.

Plans for implementing alternate water sources will be finalised.

Level 5 (Emergency)

Level five restrictions will aim to reduce normal average daily household consumption by 50% to a target level of 190-160 litres per person per day (L/P/d). During this stage all non-essential water related activities are banned. Alternative water supply plans including the carting of water to the supply system, intermittent closing of the reticulation system, etc. may be implemented.

4.3.3 Demand Side Activities

In combination with water restrictions, Council will also undertake the following activities to assist in managing the demand on the water supply:

- Public education, information and awareness campaigns;
- Provide information on storage levels and water use;
- Provide tools and resources to assist people in managing their water use and adhering to restrictions;
- Implement Emergency Procedures: Provision for fire-fighting; and
- Intermittent closing of the reticulation system.

Table 4-3 Water Restrictions Table

Type of Consumer	Permanent water conservation	Level 1 Restrictions	Level 2 Restrictions	Level 3 Restrictions	Level 4 Restrictions	Level 5 Restrictions
Target reduction		10% reduction	10-20% reduction	20-30% reduction	30-40% reduction	40-50% reduction
DOMESTIC						
Fixed hoses / sprinklers	No unattended hoses. No watering between the hours of 9am and 4pm. Vehicles should only be washed on grassed or permeable surfaces. Washing of hard surfaces with hand held hose is not permitted at any time.	Maximum 15 minutes per day between 4:00pm and 9:00am	Maximum 15 minutes per day between 4:00pm and 9:00am	Not permitted. Bucket watering permitted.	All external use of potable water is banned. Grey water use only	All external use of potable water is banned. Grey water use only
Micro sprays / drippers / subsurface						
Hand held hoses		Maximum 1 hour per day between 4:00pm and 9:00am. One hose per property.	Maximum ½ hour per day between 4:00pm and 9:00am. One hose per property.	Maximum 10 minutes per day between 4:00pm and 9:00am. One hose per property.		
Swimming Pools and Spas		Filling permitted – no unattended hoses	Filling of new or existing pools is banned. Topping up of pools is allowed by handheld hose 1hr/day outside of the hours of 8am and 4pm	Filling of new or existing pools is banned. Topping up of pools is allowed by handheld hose 1hr/day outside of the hours of 8am and 4pm	Filling of new or existing pools is banned. Topping up of existing pools to 300mm below skimmer box by one hand held only, 1hr/week on Wednesdays.	Filling and topping up of pools banned.
Car Washing		No restrictions – no unattended hoses	Buckets only	Buckets only	Cleaning of windows, windscreens, lights and mirrors with buckets.	Cleaning of windows, windscreens, lights and mirrors with grey water.
Washing Hard Surfaces					Banned	Banned
BUSINESS / COMMERCIAL PREMISES ETC.						
Public gardens, sports grounds & community facilities	No unattended hoses. No watering between the hours of 9am and 4pm.	As per residential restrictions. Exception: sprinklers or micro sprays may be used up to 2hrs/day for essential businesses (e.g. nurseries) or where business hours dictate water use, e.g. schools	As per residential restrictions. Exception: sprinkler may be used up to 2hrs/day for essential businesses (e.g. nurseries) or where business hours dictate water use, e.g. schools	Hand held hoses allowed for 1 hour per day outside the hours of 8am and 4pm	Buckets or watering cans only	Use of town water is banned
Nurseries				Sprinklers and hand held hoses allowed for 2hrs/day. Application for times.	Sprinklers/hand held hoses 1hr/day – application for times.	Use of town water is banned
Bowling Greens				Hand held hoses allowed for 1 hour per day outside the hours of 8am and 4pm	Buckets or watering cans only	Use of town water is banned

Type of Consumer	Permanent water conservation	Level 1 Restrictions	Level 2 Restrictions	Level 3 Restrictions	Level 4 Restrictions	Level 5 Restrictions	
New turf / landscaping	Newly laid turf may be watered with water conserving equipment for a period of up to six (6) weeks from the installation of the turf.			Water in – then hand held hoses 1 hour per day outside hours of 8am and 4pm		Use of town water is banned	
Public pools	No unattended hoses between the hours of 9am and 4pm	Filling permitted – no unattended hoses	Filling of pools is banned. Topping up of pools is allowed by handheld hose 1hr/day outside of the hours of 8am and 4pm	Topping up allowed	Topping up with alternative water supply permitted. Town water use not permitted.	Topping up with alternative water supply permitted. Town water use not permitted.	
Washing motor vehicles ¹ – cars, taxis, food transport, commercial etc.		No restrictions – no unattended hoses	Buckets only on grassed areas. Exemption may be granted if proof of water efficient devices provided	Buckets only on grassed areas. Exemption may be granted if proof of water efficient devices provided	Buckets only on grassed areas. Exemption may be granted if proof of water efficient devices provided	Buckets only on grassed areas. Exemption may be granted if proof of water efficient devices provided	Use of town water is banned
Building construction			No restriction on essential business use	No restriction on essential business use	Restricted to essential business use.	Use of town water is banned	
Paved public areas; where food is prepared or consumed or for health reasons			Hand held hoses 1hr/day – eating / preparation areas for health reasons only	Hand held hoses 1hr/day – eating / preparation areas for health reasons only	Buckets or watering cans – eating / preparation areas for health reasons only	Buckets or watering cans – eating / preparation areas for health reasons only	
Water cartage – potable supply			Filling of domestic tanks only – private carriers must be registered.	Filling of domestic tanks only – private carriers must be registered.	Council approved private water carters only	Use of town water is banned	
Auto flush urinals / public toilets			On timers – banned On Demand - ok	On timers – banned On Demand - ok	On timers – banned On Demand - ok	On timers – banned On Demand - ok Public toilets closed	
INDUSTRIAL							
Ready mix concrete & other industrial operations	No unattended hoses between the hours of 9am and 4pm	No restriction on water usage for essential business activities	No restriction on water usage for essential business activities	Restricted to 8 hours / day operations	Council Approved	Use of town water is banned	
RURAL							
Stock watering	No restriction	No restriction	Council Approved	Council Approved	Council Approved	Use of town water is banned	

¹Emergency vehicles are exempt, but are encouraged to be water wise

4.4 Supply-Side Action Plan

When drought occurs, actions must be taken to mitigate the effects of water shortage and to ensure that a reliable water supply is available to meet the health and safety needs of the community. Supply-side actions are actions taken by Council aimed to supporting the restrictions as well as preparing for worsening situations.

4.4.1 Staged Action-Plan

Drought management supply-side actions should be implemented while the community, guided by Council, takes action to reduce water demand using water restrictions. The supply actions are proposed to be implemented within a timeframe so that water supply is sufficient to sustain the estimated water demand at the particular water restriction level. The supply-side actions are actions that Council will undertake to continually supply water to its customers during drought. Alternative water supply options are described in Section 6.2.2.

Table 4-4 lays out how supply actions are implemented as restriction levels are increased.

Table 4-4 Staged Drought Supply-Side Actions

Level	Supply Side Activity
Permanent	<ul style="list-style-type: none"> • Investigate the availability of additional water allocations • Increase the effectiveness of extraction of water at existing locations
Level 1 Low	<ul style="list-style-type: none"> • Investigate use of treated effluent to replace drinking water for external watering of Council assets, sporting fields etc. • Commence procedure to acquire allocations
Level 2 Moderate	<ul style="list-style-type: none"> • Negotiate access to water with owners of alternative water sources • Investigate water delivery by pipeline(s) from alternative sources within and outside the service area • Investigate groundwater sources including water quality testing (Urbenville) • Design and prioritise engineering projects: <ul style="list-style-type: none"> ○ Pipelines ○ Bores ○ Recycled water systems
Level 3 High	Construction of long lead time projects
Level 4 Very High	Construction of short lead time projects
Level 5 Extreme	Water carting

4.4.2 Water Carting

In the event of Tenterfield water supply needing a supplement water source to be carted into the reservoir the use of an appropriately ample water supply would be commissioned. With a normal period usage of 1.2 ML/day from the system with a stage five restriction target of 50% reduction of daily volumes this will see a new daily needed volume of 0.6 ML/day. This would be possible from the carting of thirty (30) 20,000L water tankers/day. There may be a need for

an additional load of water to be transported intermittently to cope with any over usage by the community.

In the event that water storages are depleted to the point where water needs to be imported from other water supplies, the use of Lismore's water supply (Rous County Council) would be most likely to be commissioned for the UMMWWS. Within a normal/daily water demand of 0.7 ML/day and a level 5 restriction target of a 50% reduction of daily use this will see a system demand of 0.35 ML/day. Twenty (20) tanker loads of 20,000L per day would suffice the demand requirements for the system.

Water carting requirements for the Jennings water supply would be mostly conducted by Southern Downs Regional Council. Depending on the drought situation, water would either come from Warwick or further afield. Council would work with Southern Downs Regional Council to ensure adequate supply.

Cost of carting

The 2019/2020 charge for bulk water from Rous County Council is \$5.75/KL. Water cartage is estimated at \$7.40/km, based on figures from 2019/2020.

Therefore, the cost of water and cartage for 1 month would equate to:

- \$1,091,160.00 for Tenterfield; and
- \$561,680.00 for Urbenville.

4.5 Monitoring During Drought

The following monitoring will be carried out during drought. Some of the items below are recorded on a regular basis as part of the water business requirements:

- Daily water demand
- Daily supply from each source (including non-drinking water)
- Daily monitoring of water sources
- Daily temperature and rainfall
- Impact of restrictions on water consumption
- Comprehensive testing of water quality from any emergency water supply, such as new bores, before commencing supply. Assistance is available from NSW Health.

- Ongoing water source quality:
 - Electrical conductivity (monthly)
 - Total dissolved solids (monthly)
 - pH (daily)
 - Alkalinity (monthly)
 - Algae levels (daily)
 - Taste and odour (on complaint)
 - Chemical analysis (monthly)
 - Microbial analysis (monthly)

A chart showing the daily demand, restriction level, temperature and rainfall is to be prepared and updates at least fortnightly.

Monitoring is intended to provide effective management of the incident. Some or all of the data may be used as part of the communication campaign. Council will continue to present the water health card for Tenterfield and Urbenville.

4.6 Communications Strategy

4.6.1 Community

Purpose

The purpose of the communication strategy is to:

- Communicate the restriction levels and expected behaviour
- Provide general information to the community and enlist its support and understanding to the actions undertaken by Council.

Channels

Some of the communication channels that may be used:

- Advertisements on radio and newspapers
- Press releases
- Information in newsletters and Councils website
- Presentation to community groups
- Signs in key locations and major roadways
- Place copies of the restriction notice and posters on community noticeboards around town and in the Cinema

- School visits to explain the restrictions to children
- Letterbox drop / mail-out of the notice and information brochure to go to all residents and businesses. This is particularly important for Urbenville.
- Rangers carrying additional brochures to be passed out where they initially warn residents
- Announcement by high profile persons (e.g. Mayor)
- Work with accommodation providers to develop a program to make hotel and motel guests aware of the restrictions in place
- Online question and answer sessions
- Presentation at community forums / drop-in sessions
- Presentation at business breakfast
- Information stalls at local markets
- Use of Council's Facebook page, if obtained in the future

Messages

Examples of messaging for posters is shown in Appendix E. The information included in the posters is what level water restriction is current, the start date of the restrictions, a summary of the key restrictions, contact details of registered water carters and where to get more information.

Comments from the community about the drought messaging indicated that people are interested in more information, particularly about dam levels, estimates of length of time remaining in the storage and actions Council are taking to secure supply. This messaging needs to come from Council, and not be found through newspapers or other forums. During the 2018 drought, the community often heard news, often alarming, from newspapers or on television, which caused additional and unnecessary angst. Council needs to ensure that messaging is getting out to the community in a timely manner and in easy to understand language. If the message isn't getting across, i.e. through reduced water consumption, then alternative messaging or forums (such as letterbox drop) may need to be considered.

It is proposed to have a dedicated drought page on the Tenterfield Shire Council's website during drought times, with a range of information, including current water supply capacities, restriction levels and water saving tips.

Contact List

Different types of information are required for different media channels.

Information such as water restrictions and water saving tips should be shared with the local media – the contacts are listed in Table 4-5.

Local community groups may also be able to assist with the distribution of this information.

Table 4-6 provides the relevant contact details. Details are provided for both areas connected to Council's potable water supply and those who are not. Both are provided as during severe drought, those who usually rely on their own water sources may need to access Council's potable water supply.

Council may also decide to share new stories about what is happening in our area with the region. The contact details of the regional media outlets are listed in Table 4-7.

Table 4-5 Local Media Contact List

Organisation	Contact Details
2 Ten FM	info@tenfm.org.au
Tenterfield Star	tenterfieldstar@austcommunitymedia.com.au
Tenterfield in Touch	news@tenterfield.nsw.gov.au
Drake Village Voice	editordvv@gmail.com
Rebel FM	admin@rebelfm.com.au
Stanthorpe Border Post	editor@borderpost.com.au
Southern Free Times	newsdesk@freetimes.com.au
Northern Star	news@northernstar.com.au
Warwick Daily News	editor@warwickdailynews.com.au

Table 4-6 Local Community Groups Contact List

Community Group	Contact Person	Contact Details
Areas connected to the potable water network		
Urbenville Progress Association	Sharyn Russ	02) 6634 1440 or 0428 666 398 secretaryofupa@gmail.com
Tenterfield Chamber of Tourism Industry Business	Mr Vince Sherry	tctib@outlook.com
Wallangarra/Jennings Progress Association	Mrs Liz Mikkelson (President)	lizmikkelson@yahoo.com.au
Woodenbong Progress Association	Mrs Christine Reid (President)	reidsonthecreek@hotmail.com
Areas connected to private water sources		
Bolivia Progress Association	Mrs Fay McCowen	bolivia1@bigpond.com
Drake School of Arts & Progress Association	Roger Turner (President)	ezwood3@bigpond.com
Drake Hall Committee	Mr Ray Woodward	ezwood3@bigpond.com
Legume Progress Association	Mrs Val Flint (Secretary)	lambgc135@gmail.com
Legume Hall Committee	Mrs Val Flint	07) 4666 4161
Liston Hall Committee Inc	Laura Simpson (Secretary)	liston.hall@gmail.com
Liston & District Progress Association	Trish Crome (Secretary)	tandtcrome@activ8.net.au
Mingoola Hall Committee	Christine Dennis	0419 441 422
Mingoola Progress Association	Mr Simon Capper (Secretary)	capper.simon@gmail.com
Sunnyside Hall Committee	Mrs Emily Smith	0432 791 754 kyarnee2@gmail.com
Steinbrook Progress Association	Marisa Lyons (Secretary)	steinbrookhall@gmail.com
Torrington Memorial Hall Fund Inc	Jan Styles (President)	torringtonhall@gmail.com

Table 4-7 Regional Media Contact List

Organisation	Contact Details
ABC North Coast	news.lismore@abc.net.au
ABC Radio Tamworth	nenw@your.abc.net.au
Glen Innes Examiner	laurie.bullock@fairfaxmedia.com.au
Janelle Saffin MP	Lismore@parliament.nsw.gov.au
The Hon Barnaby Joyce MP	barnaby.joyce.mp@aph.gov.au
NBN TV Tamworth	tamnews@nbntv.com.au
Northern Daily Leader	mail.ndl@fairfaxmedia.com.au
Northern Star	news@northernstar.com.au
Prime 7 Tamworth	Tamworth.news@prime7.com.au
Ten Network Tamworth	enquire@mcn.com.au

4.6.2 Agencies

Purpose

The separate communication strategy is required for regulators, other government agencies, water managers and neighbouring Councils in order to:

- Share resources for managing the drought
- Apply for regulatory and financial support as required
- Obtain access to alternative water sources.

A list of relevant contacts are provided in Table 4-8.

Table 4-8 Agencies Contact List

Organisation	Name	Phone	Email
DPIE	Mark Watson	0409 114 384	mark.watson@dpi.nsw.gov.au
EPA	Daniel Stokes	0499 000 729	daniel.stokes@epa.nsw.gov.au
NSW Health	Glenn Pearce	0429 100 391	glenn.pearce@health.nsw.gov.au
Kyogle Council	Tony Lickiss	02) 6632 1611	Tony.Lickiss@kyogle.nsw.gov.au

Organisation	Name	Phone	Email
Southern Downs Regional Council	Jill Yeaman	0439 394 464	Jill.Yeaman@sdr.c.qld.gov.au
Glen Innes Severn Council	Keith Appleby	0408 144 251	kappleby@gisc.nsw.gov.au
Rural Support Service	Jodie Magner	0429 995 189	jodie.magner@dpi.nsw.gov.au
Hunter New England Local Health Unit	Kelly Foran	0402 292 005	Kelly.Foran@health.nsw.gov.au
Critical Customers - Tenterfield			
Tenterfield Hospital	Tony Roberts	02) 6739 5200	
Haddington Nursing Home	Fiona Murphy	02) 6736 4713	ceo@tenterfieldcarecentre.org.au
Millrace Hostel			
Tenterfield Preschool	Chloe Daly	02 6736 1616	admin@tenterfieldpreschool.com.au
Tenterfield Childcare Centre	Carly Fitzgerald	02) 6736 1387	director.tentccc@outlook.com
Sir Henry Parkes Memorial Primary School	Anna Starcevic	02) 6736 1401	sirhparkes-p.school@det.nsw.edu.au
St Joseph Primary School	Cherie Yates	02) 6736 1786	tenadmin@arm.catholic.edu.au
Tenterfield High School	Stephanie Scott	02) 6736 1200	tenterfiel-h.school@det.nsw.edu.au
TAFE			
Tenterfield Fire and Rescue	John Gray	02) 6736 3835	
Tenterfield RFS	Chris Walbridge	0428 657 647	northern.tablelands@rfs.nsw.gov.au
Critical Customers - Urbenville			
Urbenville Hospital	Dr Katherine Willis-Sullivan	02) 6620 2353	

Organisation	Name	Phone	Email
<i>Urbenville Public School</i>	Christopher Sifko	02) 6634 1333	urbenville-p.school@det.nsw.edu.au
<i>Urbenville RFS</i>			urbenvillerfs@gmail.com
<i>Woodenbong Central School</i>	Greg Wilson	02) 6635 1281 0429 684 212	woodenbong-c.school@det.nsw.edu.au
<i>Woodenbong RFS</i>	Greg Gulliver	0476 152 252	
Critical Customers - Jennings			
<i>Jennings Public School</i>	Shannon Booby	07) 4684 3273	jennings-p.school@det.nsw.edu.au

5 Drought Recovery Strategy

The recovery process will commence at the end of the response operations. The end of the drought should start with the Chief Executive revoking drought conditions. The DMT will cease operation, but members will still be available to assist the Recovery Coordinator, mainly debriefing and assessing the response.

A Recovery Coordinator will be appointed by the DMT to oversee the recovery process. The Recovery Coordinator will be responsible for:

- Preparing a response report and recommending actions based on the experience. The report will be submitted to the Chief Executive within 4 weeks of revoking the drought condition and to Council within 8 weeks. Once endorsed by Council, the report will become the main component of the preparedness stage.
- Assessing the remaining drought impact and determining the appropriate personnel to coordinate the recovery activities. This will be based on the drought recovery survey described below.

A drought recovery survey will be developed to evaluate the recovery process needed to restore the physical infrastructure and the restoration of emotional, social, economic and physical wellbeing. The drought recovery survey will assess the following criteria in order to determine the recovery actions required:

- **Ownership:** Determine the ownership of private or public asset and the source of assistance that might be available
- **Severity of impact:** Develop a scale to determine the severity of social, economic and financial impact to be based upon
- **Time to recover:** evaluate a timeframe required to recover from the drought
- **Cost of impacts:** the financial loss due to the drought impact
- **Resources required:** resources (financial and others) required to complete the recovery process.

With the outcomes of the drought recovery survey, Council will be able to seek the appropriate resources to address the recovery needs. The recovery process

will involve restoring the community to the point where normal social and economic activities may resume.

Council will not compensate private customers for costs or financial losses caused by the drought. Council, along with other agencies, will assist customers and coordinate activities associated with seeking compensation from other sources such as government and insurance companies.

When the drought period is considered over and the conditions return to normal, the following actions are to be considered:

- Reviewing the Drought Management Plan and actions in the light of experience
- Insurance compensation
- Government assistance
- Liaise with tax office to provide tax relief (reduction or delay of payment deadlines)
- Develop rehabilitation/recover programs based on the drought recovery survey
- Ensure fire control programs are in place
- Assist the community in resolving conflicts.

6 Tenterfield Water Supply Scheme

6.1 Existing Water Supply Scheme

The Tenterfield water supply consists of the Tenterfield Dam (Figure 6-1) with a water treatment facility located adjacent to the dam wall. The water is treated via chemical coagulation and sedimentation, with a deep bed filtration system. It is then sterilised using UV and a chlorine residual. The filtered water is then pumped to the reticulation system with one water storage reservoir located at each end of the town on hills. The dam has a capacity of 1,300 ML¹ with an average daily demand of 1.2 ML/day supplied to the community. Figure 6-2 shows the revised water depth–storage curve for Tenterfield Dam. Further information on the Tenterfield Dam capacity can be found in Appendix F. Bulk water can be purchased through an automatic filling station that was installed in August 2018.

The town water system is also supplemented with a series of bores. The original bores were installed in 1994 with a production bore at Shirley Park and a livestock bore at Apex Park. During the 2018 drought, seven new bores were installed as production bores, which will feed through a pre-treatment before entering the treatment plant. A map of the bore network is shown in Figure 6-3.

Figure 6-4 shows a schematic of how the Tenterfield water supply system operates. Apex Park bore is not included on this diagram, as it provides non-potable water only, which is available through an isolated system.

¹ The capacity of the dam was assessed in February 2020 with bathymetric and sediment survey's undertaken of the dam by Water Modelling Solutions.



Figure 6-1 Tenterfield Creek Dam

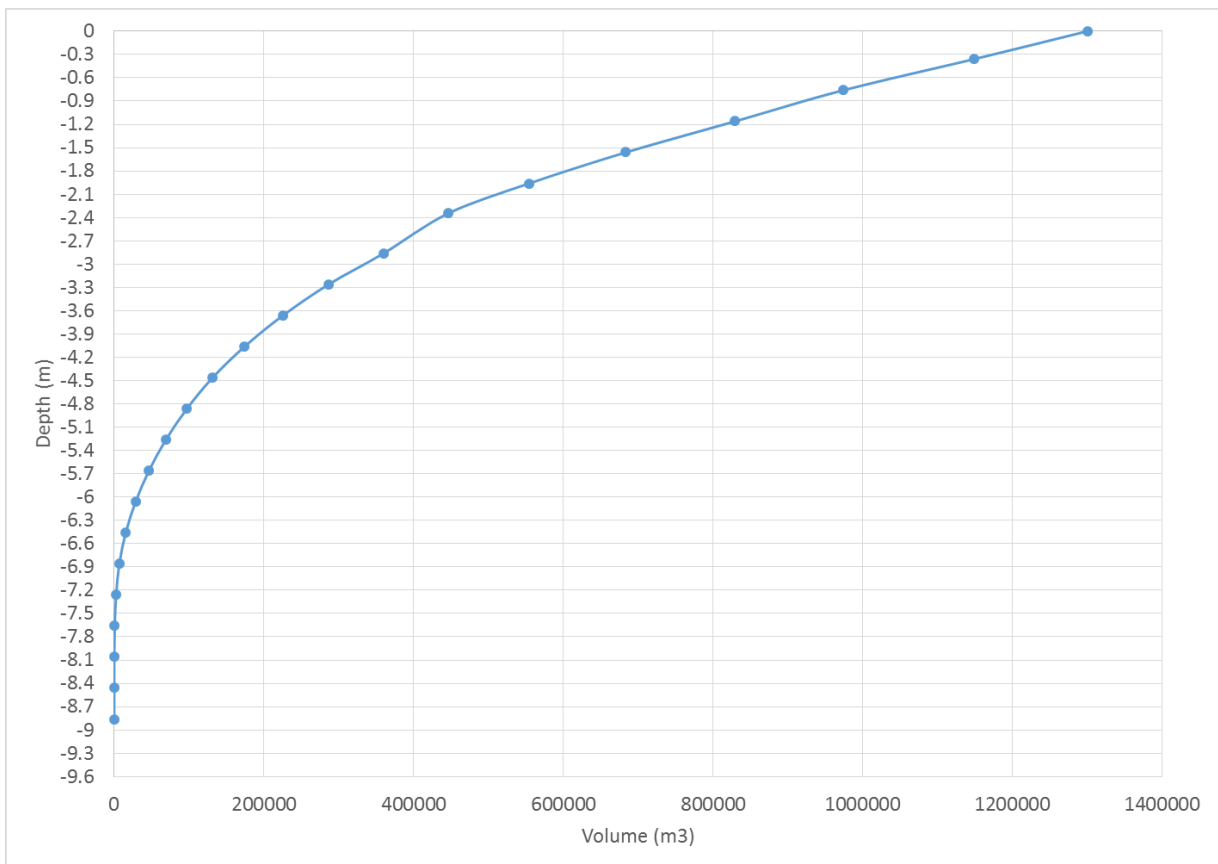

Figure 6-2 Water Depth-Storage Curve for Tenterfield Dam

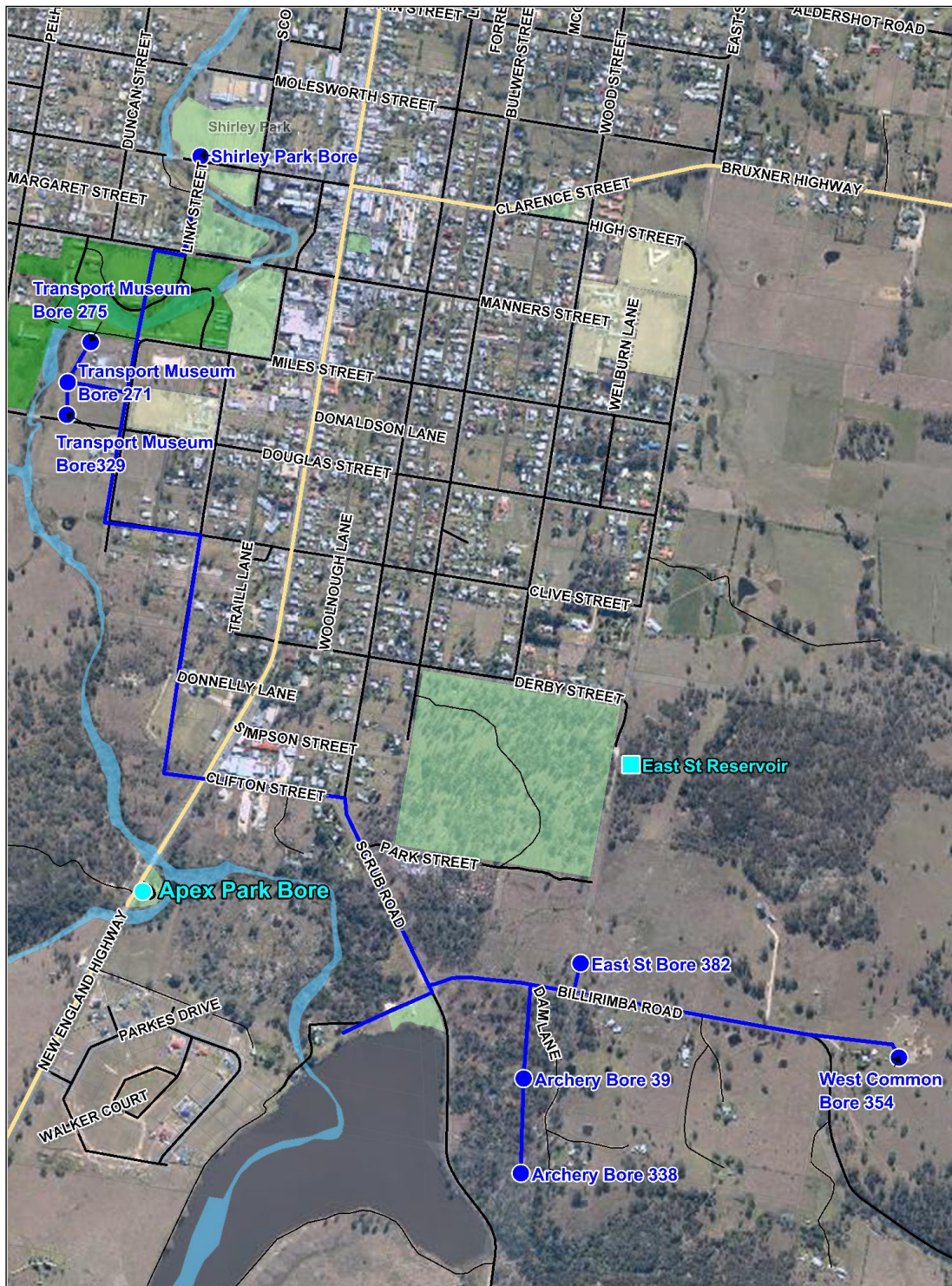

Figure 6-3 Tenterfield Bore Network

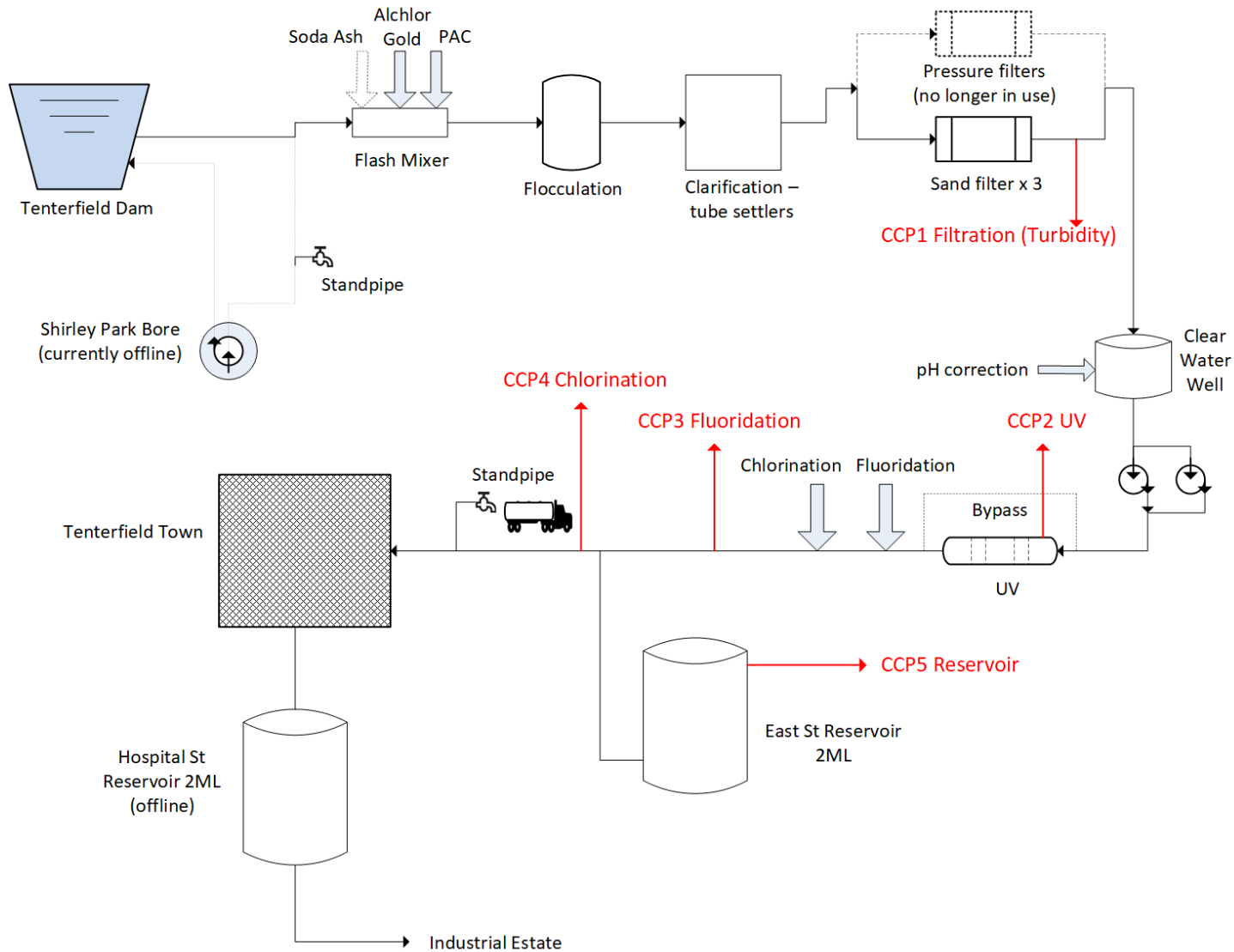

Figure 6-4 Tenterfield Water Supply Schematic (Viridis, 2018)

6.2 Water Sources

6.2.1 Existing Sources

Council has a licence for **Tenterfield Dam** (WAL 6491), issued through the NSW Department of Industry as part of the NSW Border Rivers Unregulated and Alluvial Water Sources 2012 Water Sharing Plan. This provides Council with the ability to extract up to 824 Mega litres (ML) per year from the Dam for the purpose of Town Water Supply. The average yearly consumption between 2009 and 2019 is 340ML.

Council also has an allocation for the **Shirley Park Bore** (WAL 31091). This licence is part of the NSW Murray Darling Basin Fractured Rock Groundwater Sources Water Sharing Plan. Council has an allocation of 160ML per year to extract for the purpose of Town Water Supply. Until 2019, the bore had not been utilised, 143ML was extracted in 2019.

Council has been granted an allocation for six bores, as part of the 2019 bore field project, including **Apex Park, Bore 39 (Archery Site), Bore 338 (Archery site 2), Bores 271, 275 and 329 (Transport Museum)** (WAL 43156). This licence is part of the NSW Murray Darling Basin Fractured Rock Groundwater Sources Water Sharing Plan. Council has an allocation of 330ML per year to extract for the purpose of Town Water Supply. Apex Park is limited to 15ML/year, Bores 271, 275 and 329 are limited to 100ML/year and Bore 39 is limited to 100ML/year.

Historical drought periods (1994-1996; 2002-2005; 2006-2008 and 2018-2020) saw stress placed upon the Tenterfield Water Network. Level 4 restrictions were imposed in 2003 which created minor levels of social and economic stress for the community. The drought period 2006-2008 was much less intense with a level 2 restrictions only enforced for a short period with little effect on the community. The 2018-2020 drought was significant and widespread. The dam reached a level of 22% and the community entered level 4.7 restrictions. The town was in water restrictions for 22 months.

Figure 6-5 shows the average daily demand consumption per person and the average monthly dam capacity for the 2018 drought event. It is overlaid with the timing of when water restrictions were introduced and the response in

relation to the consumption. During this drought, the average consumption was 214L/person/day or 0.87ML per day for the township. During non-drought conditions, the average daily consumption for the town is 1.3ML.

There were many fires in the region during 2019, with a bushfire threatening Tenterfield township in September 2019. There were also fires in Drake in March 2019 and October 2019. These fires required water to be taken from the Tenterfield reticulation system, either from hydrants for water trucks attending the fire sites, donations of water to the evacuation centre or directly from the Tenterfield Dam. Farm dams and private water supplies were also utilised, meaning that some residents in the area might have had to purchase additional water. Residents were also purchasing additional water to ensure that there was enough water on-site to manage the fire risk. All of these put additional strain on our water supply system.

Figure 6-6 shows the average monthly rainfall and dam capacity, showing the response of the catchment to rainfall for the 2018 drought.

Figure 6-7 shows the bulk water purchases during the drought period. Figure 6-8 shows the water use from Apex Park bore during its operation. This shows that 3,015 KL of potable water was offset through the use of non-potable water from Apex Park. This facility would be made available earlier during the next drought, potentially having a larger impact on reducing potable water use.

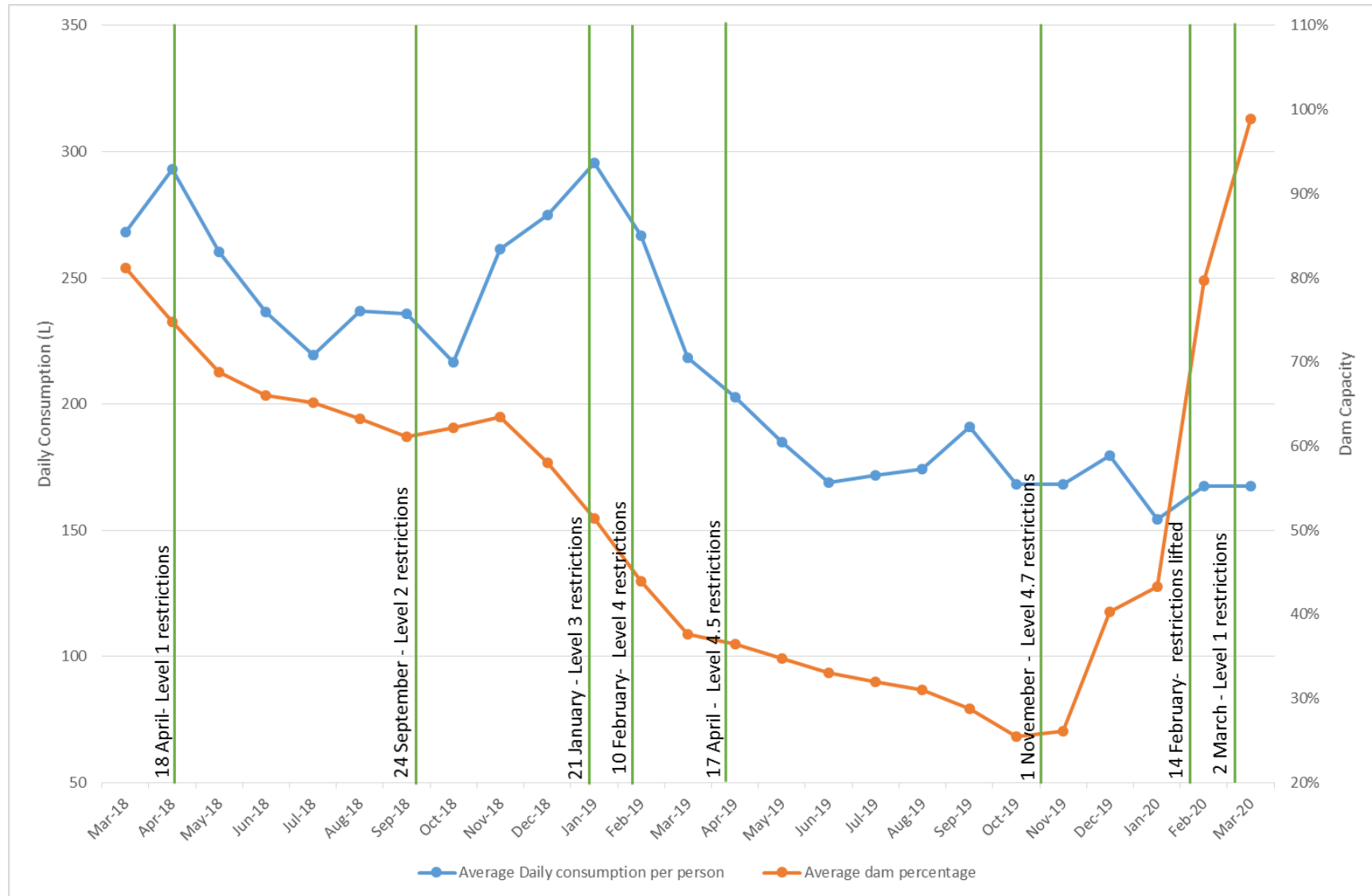

Figure 6-5 Average Consumption Vs Dam Level 2018 Drought

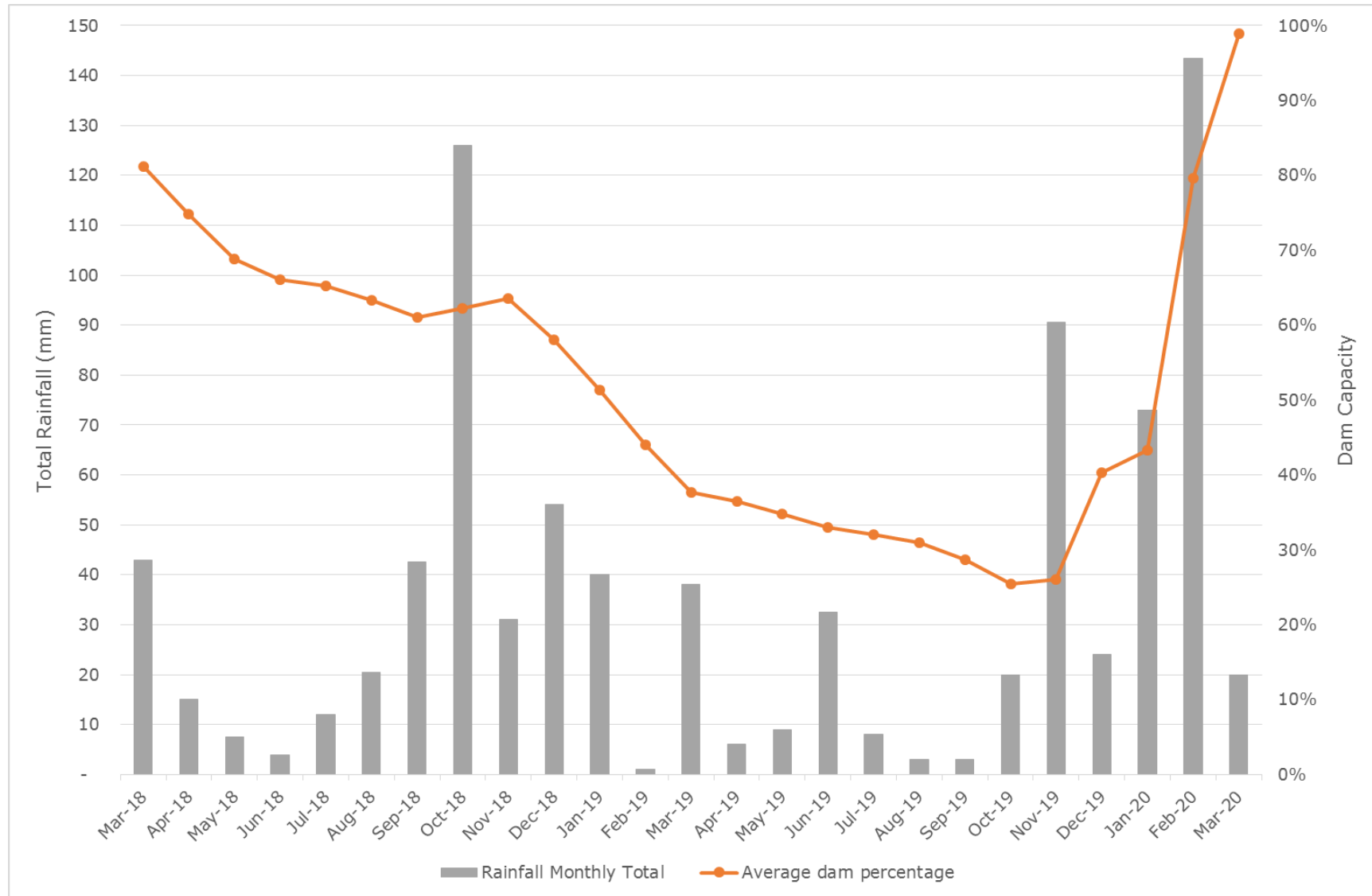

Figure 6-6 Average Monthly Rainfall Vs Dam Capacity 2018 Drought

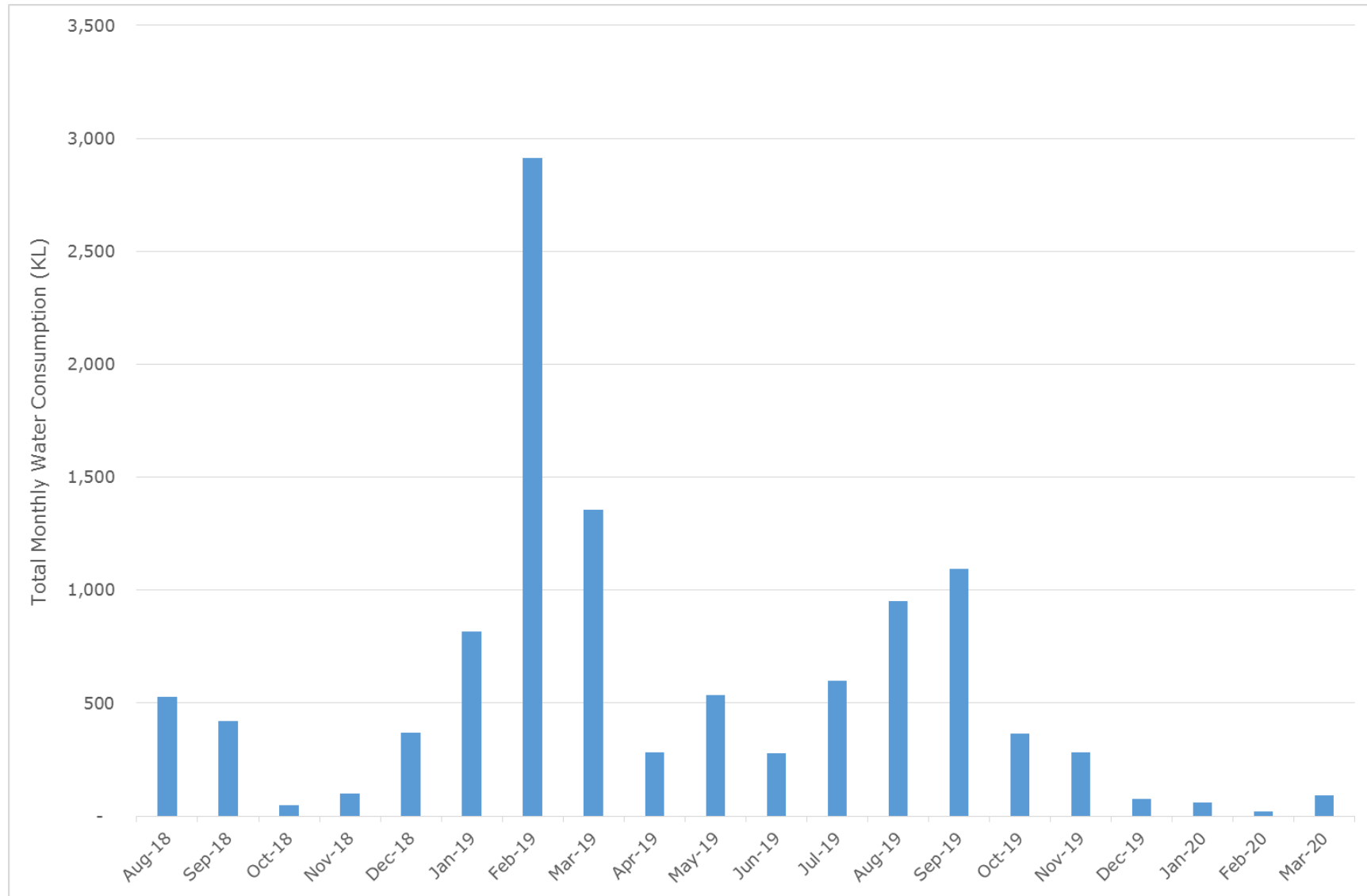

Figure 6-7 Bulk water purchases during drought period

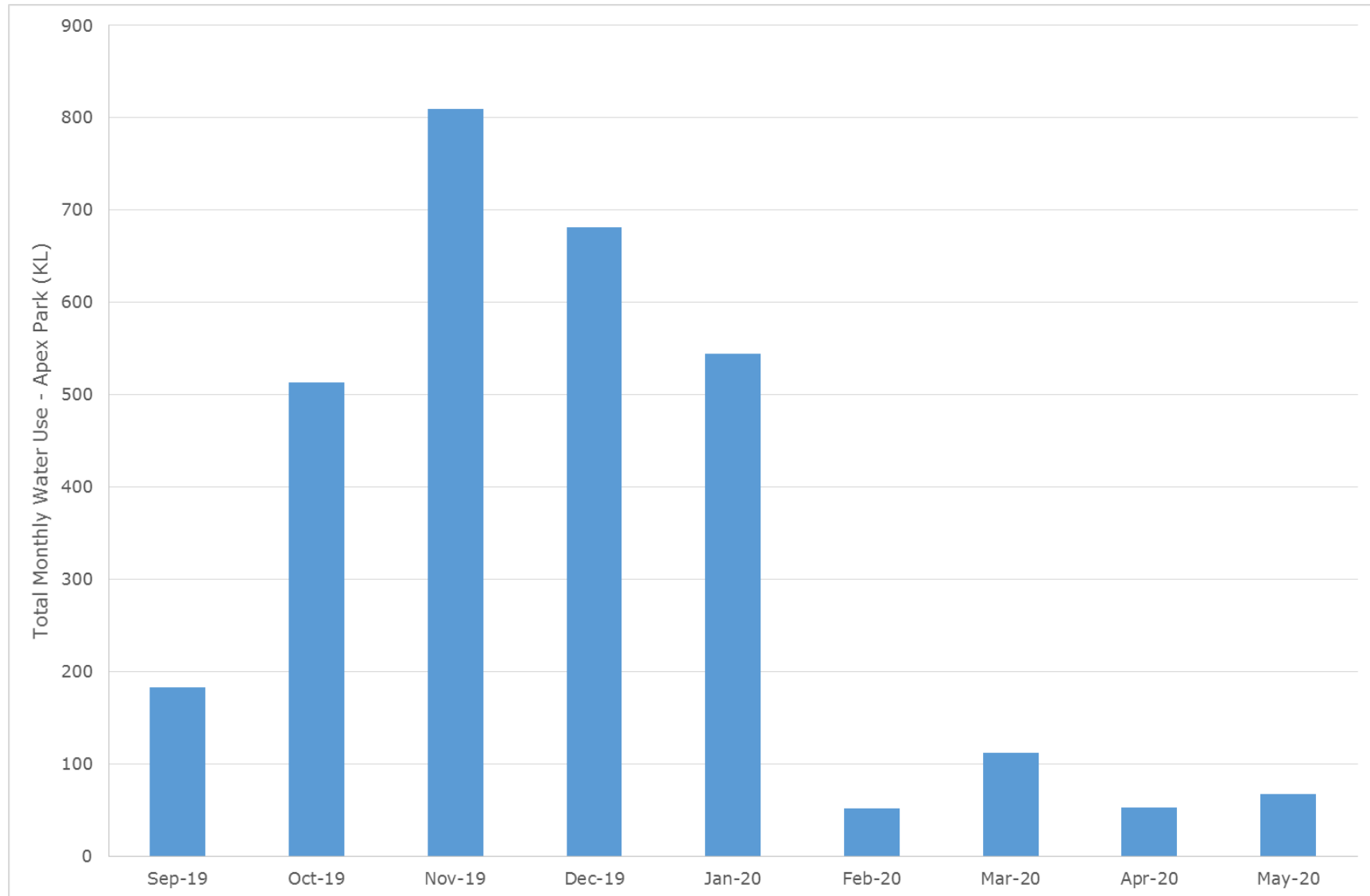

Figure 6-8 Consumption of non-potable water from Apex Park during drought period

6.2.2 *Potential Sources*

During the bore drilling program in 2019, a number of alternative bore sites were identified. These were not drilled for a number of reasons, including depth of bore, distance to treatment plant, site restraints and political issues. These sites have been surveyed and have the potential to be reassessed in the future if required.

Recycled water from the Tenterfield Sewer Treatment Plant (STP) is currently being used by the Tenterfield Golf Club for watering their facility. This arrangement was put in place in 1980's and allows them access to half of the water produced by the plant. The other half was allocated to Gungel Farm, but they have not extracted water since 2011, when their pumps were damaged. The remainder of the water is discharged into Tenterfield Creek. On average, there is 270ML² per year available in the tertiary ponds. During the 2018 drought, this dropped to an average of 240ML / year. Historically, the Golf Club uses an average of 54ML / year, but during drought conditions, this increased to a maximum of 120ML / year. Discussions with the Golf Club during the 2018 drought indicated that they require a minimum of 1.5 ML/week (78 ML/year) to ensure that the greens and trees survive. Some of the STP wastewater is also used around the plant, which account for approximately 1.3ML/week (70ML/year) – this includes the evaporation from the ponds. Therefore, assuming Gungel continue to not use the water, there is potentially a surplus of between 0.1ML/day to 0.3ML/day (50ML/year to 122ML/year) that could potentially be used during drought conditions for non-potable uses. It should be noted, that depending on the use, additional treatment may be required. A potential option is to use the excess water (treated) to inject into the underground water system. However, the volumes available versus the cost to do so may not be viable. Additional research into this option would be required if it is to proceed.

Water from the sediment pond at the Tenterfield Water Treatment Plant (WTP) has been used in the past for road building and maintenance activities during times of drought. This water has also been used to assist with public tree

² Based on data from 2010 to 2019

watering during times of drought. This source of water cannot be used as a potable drinking supplement, but it can take some burden off the drinking water system through the uses described above. The new WTP that is being built is going to have a water efficiency of $\geq 95\%$. This is much more efficient than the existing plant, meaning that there will be less water available for use during drought times.

7 Urbenville, Muli Muli, Woodenbong Water Supply Scheme

7.1 Existing Water Supply Scheme

The Urbenville, Muli Muli, Woodenbong Water Supply (UMMWWS) scheme draws its raw water from Tooloom Creek. This water supply is a natural weir pool (Figure 7-1) above Tooloom Creek Falls and has a storage capacity of approximately 240ML³. The Urbenville Water Treatment Plant (WTP) is a Dissolved Air Flotation (DAF) system that was opened in 2010. Daily demand from the water supply is approximately 0.7 ML/day. Figure 7-2 shows a schematic of how the UMMWWS system operates. Currently there is no secondary supply.



Figure 7-1 Tooloom Creek intake – UMMWWS Scheme

³ Note, this figure is not accurate, it is based on as designed estimates. Capacity is likely to be less. Survey of the site is being scheduled for 2020/2021 financial year.

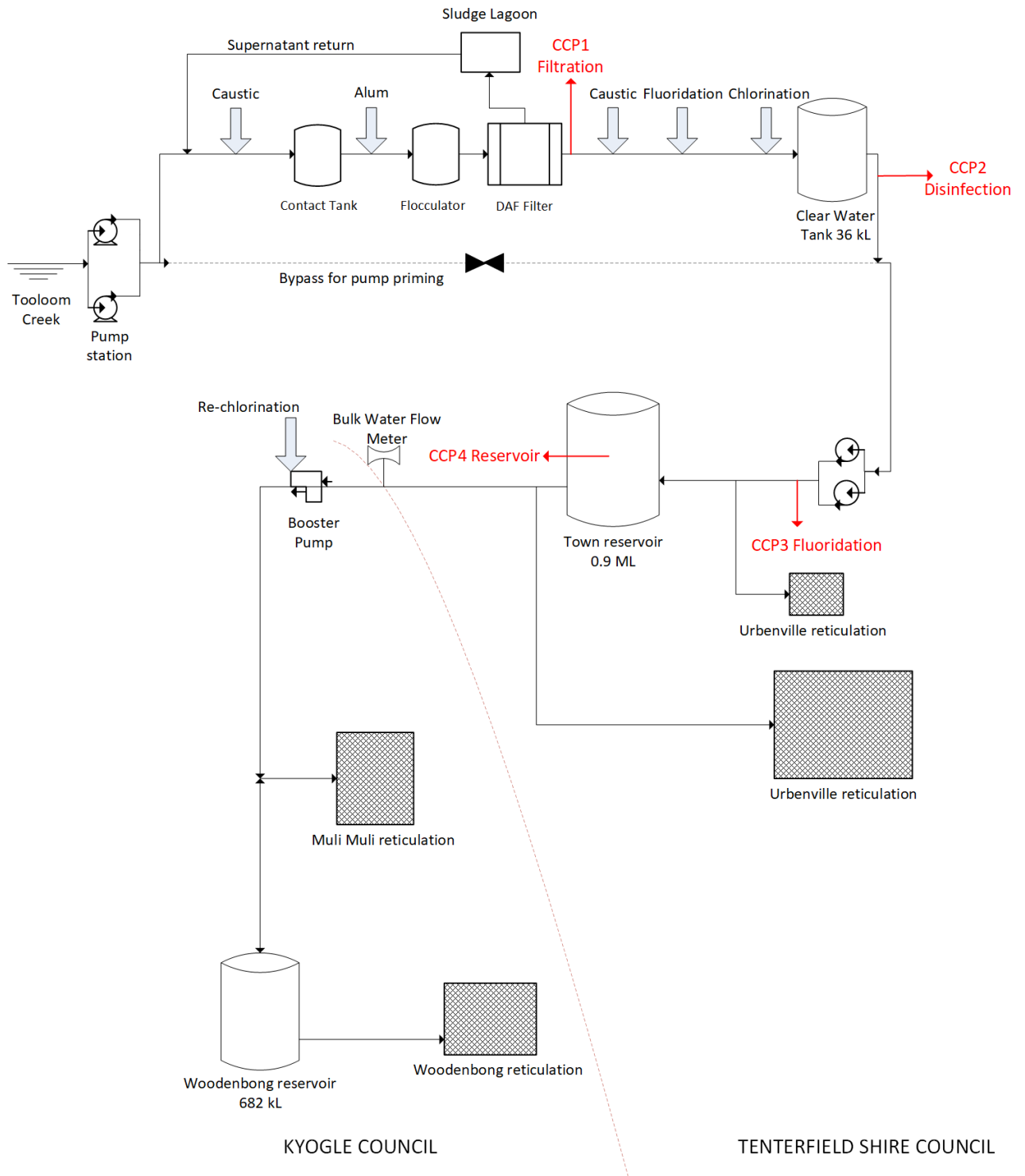

Figure 7-2 Urbenville Water Supply Schematic (Viridis, 2018)

7.2 Water Sources

7.2.1 Existing Sources

Council has a licence for water extraction from Tooloom Creek (WAL 38828), issued through the NSW Department of Industry as part of the Clarence River Unregulated and Alluvial Water Sources 2016 Water Sharing Plan. This provides Council with the ability to extract up to 175 mega litres (ML) per year from Tooloom Creek for the purpose of Town Water Supply. The average yearly consumption between 2010 and 2019 is 81ML.

There have been three historical drought periods affecting Urbenville; 2002-2005, 2007 and 2018-2020. The 2002-2005 drought had low water level dropping at the weir, resulting in level 2 water restrictions. The 2007 drought was the most severe in the region, resulting in Level 5 water restrictions. Urgent works were undertaken at that time that allowed access to a further 80 ML of low level storage in the weir pool. During the 2018-2020 drought, level 3 water restrictions were in place for a period of 3 months. The weir level dropped to a minimum of 36% during this time.

Figure 7-3 shows the average daily demand consumption per person and the average capacity of the weir for the 2018 drought event. It is overlaid with when water restrictions were introduced and the response in relation to the consumption. During this drought, the average consumption was 239L/person/day.

Figure 7-4 shows the average monthly rainfall and weir capacity, showing the response of the catchment to rainfall for the 2018 drought.

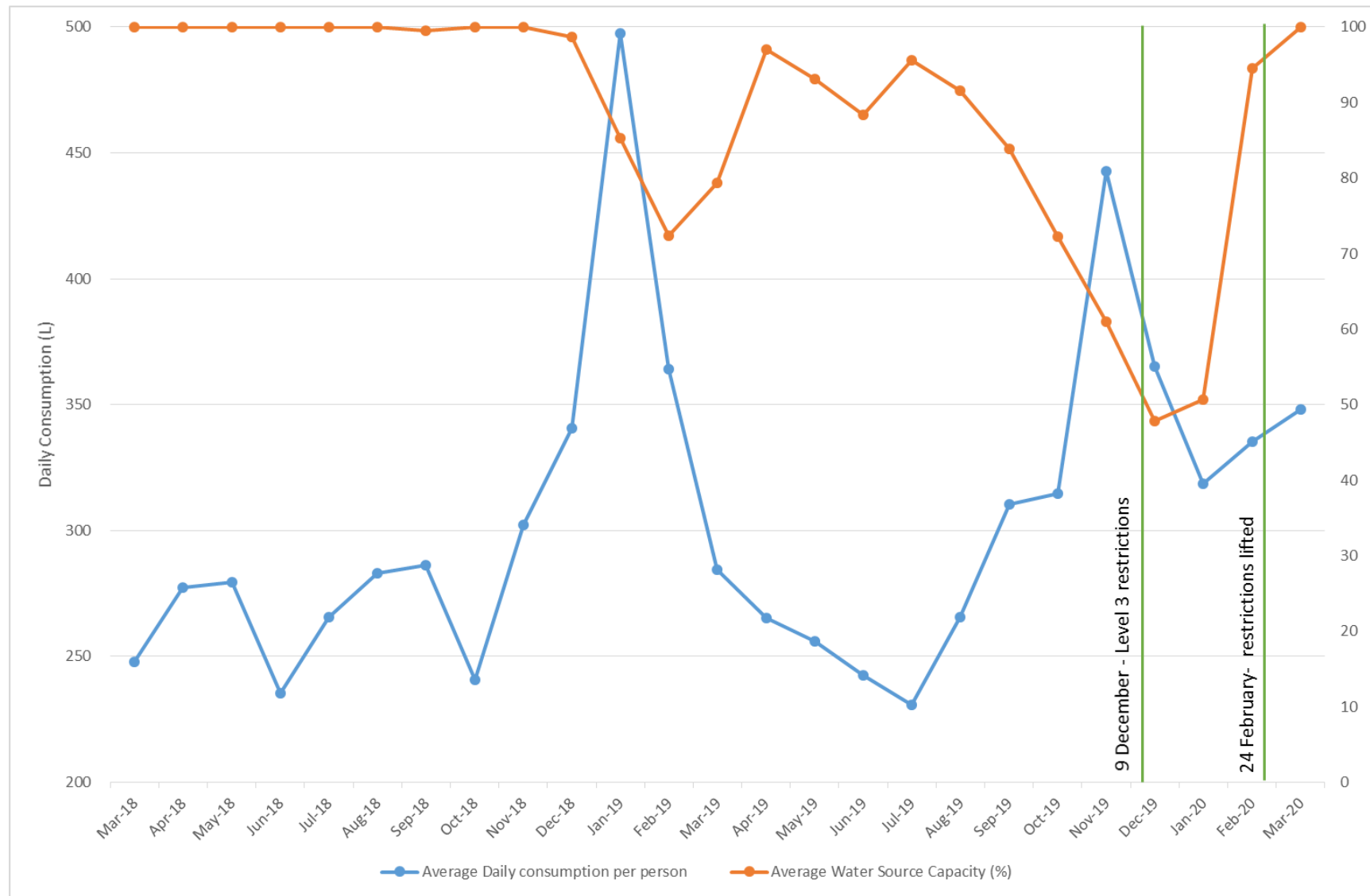

Figure 7-3 Average Consumption Vs Weir Level 2018 Drought

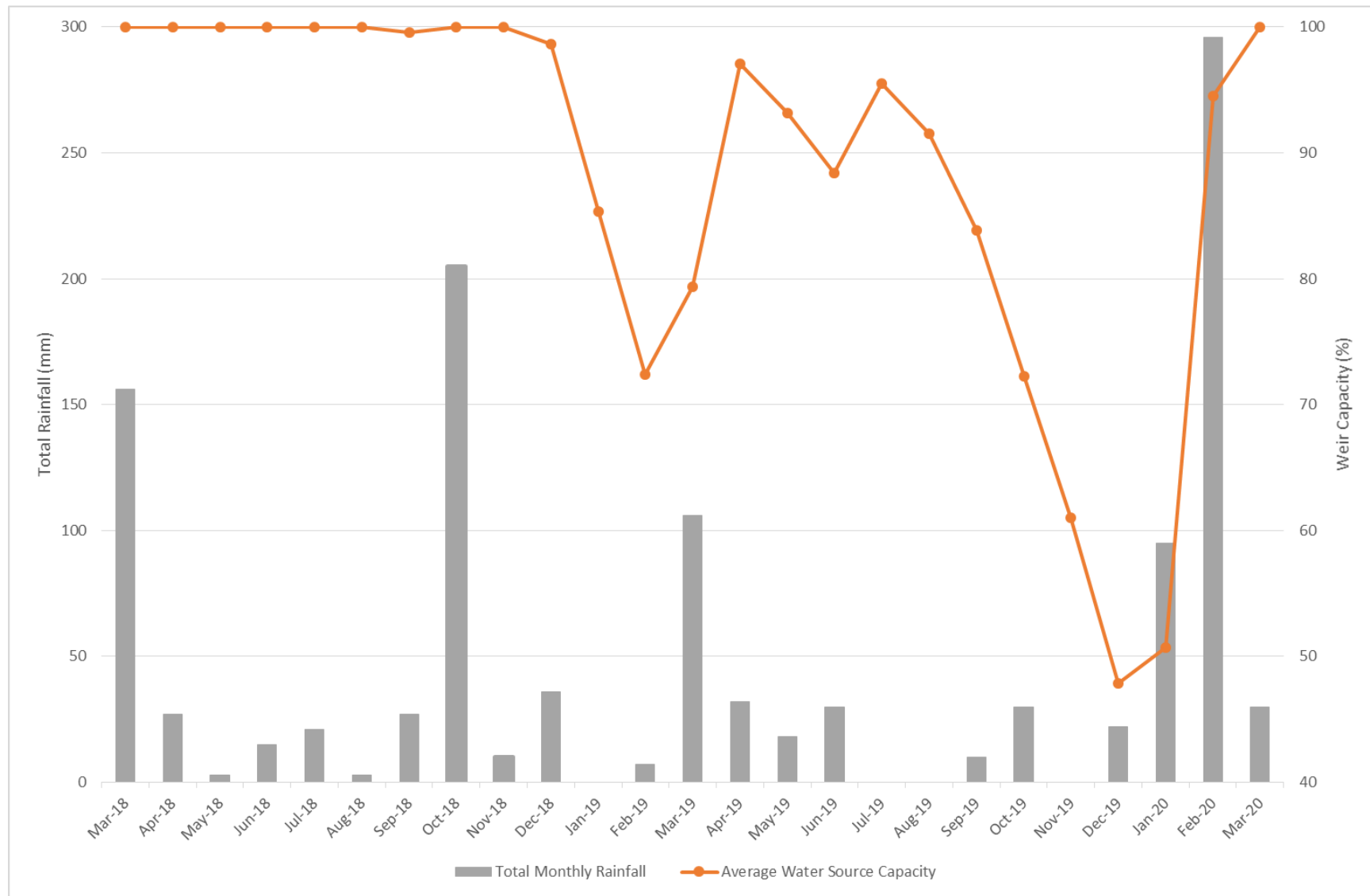

Figure 7-4 Average Monthly Rainfall Vs Weir Capacity 2018 Drought

7.2.2 Potential Sources

During the 2018 drought, Council and Kyogle Council engaged a water diviner to give an indication if bore water may be able to be found in Urbenville. The drought broke before Council could get emergency funding to augment the Urbenville Supply Scheme. Council are currently in the process of obtaining funding to continue investigations into a bore water supply for Urbenville.

Council are also investigating the option of an off-stream storage. This would create an additional storage area for water extracted from Tooloom Creek. The off-stream storage would have another benefit of improving the raw water quality. This means that the Urbenville WTP will operate more efficiently and provide a more uniform water quality.

Inflows into the Urbenville Sewer Treatment Plant (STP) is on average 17ML per year. The effluent water is currently used for environmental flows only. It is not proposed to use this water for potable water use, however, there may be businesses in the area that may be able to use the water for non-potable uses, with appropriate treatment. This could reduce the demand on the water supply scheme. Council will investigate options for use of this non-potable water source. It should be noted that additional treatment may be required.

8 Jennings Water Supply Scheme

8.1 Existing Water Supply Scheme

The community of Jennings, which sits adjacent Wallangarra, has a number of different options for water supplies that may be used to service the community. These water sources include the Beehive Dam, the Soak, the Wells, and Cusack's Dam. All water sources have been labelled by Southern Downs Regional Council (SDRC, 2018) as unreliable water sources as have a history of drying up, with the exception of Cusack's Dam.

Figure 8-1 shows a schematic of how the Jennings Water Supply Scheme works.

The Wallangarra Water Treatment Plant is managed by SDRC and was upgraded in 2018. The plant has a treatment capacity of 2ML. The water is treated via coagulation, flocculation, clarification, filtration and chlorination.

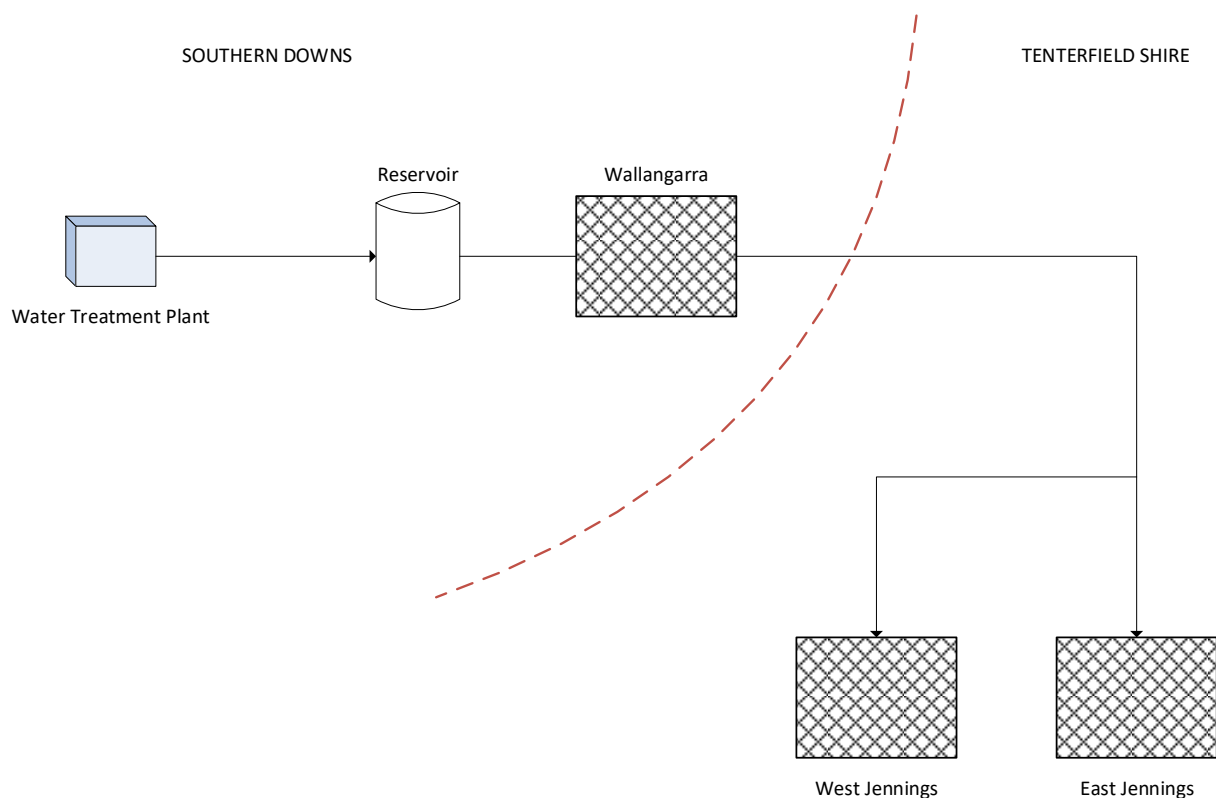

Figure 8-1 Jennings Water Supply Schematic (Viridis, 2018)

8.2 Water Sources

8.2.1 Existing Sources

Southern Downs Regional Council holds the water licences and agreements for this supply scheme.

Historically, the town experienced level 3 water restrictions due to the 2008 drought. The abattoir that was operating during that time had a large impact on the water security of the community. This abattoir is no longer in operation.

The 2018 drought has been severe for SDRC. During this period, Emergency restrictions were introduced in November 2019, aiming for a water use of 80L per person per day. For the 2018/2019 financial year, Jennings was using an average of 166L/person/day. In the 2019/2020 financial year, Jennings was using an average of 94L/person/day.

8.2.2 Potential Sources

Council will have discussions with Southern Downs Regional Council about potential alternative water sources.

Jennings is currently a septic system – this eliminates the option of using recycled water on a community scale.

9 Water Demand

9.1 Water Pricing

Council's water supply needs to achieve cost recovery, meaning that the water income needs to support both the operating and capital expenditure.

During the 2018/2020 drought, Council's water supply was not achieving cost recovery and was operating at an average 20% deficit. This has resulted in an increase in water price after the drought to ensure cost recovery in the future, while the water usage remains low. The pricing will return to the pre-drought costings when the usage increases by 10% or more, as this will ensure full cost recovery.

Historically, water pricing has not been required to be used as a price signal to communicate the seriousness of the drought. The communities have adequately responded to water restrictions, curbing their water use to ensure the longevity of the water sources.

9.2 Water Users

Tenterfield Shire has three areas that are supplied with potable water: Tenterfield, Urbenville and Jennings. The other towns in the Shire are typically self-reliant, relying on rain, creek and bore water. Details of each town are provided in Table 9-1. There are many smaller townships in our region that have not been included in the table below. These areas account for 13% of the Shire's population.

Table 9-1 Water Demand for the Shire Townships

Township	Population Demand	Number of Connections	Average Daily Demand (ML/d)	Water Sources
Tenterfield	4,040	1,897	1.20	Tenterfield Dam Bores
Urbenville / Muli Muli / Woodenbong	787	357	0.70	Tooloom Creek
Jennings	160	93	0.02	Beehive Dam, the Soak, the Wells, Cusack's Dam
Drake	345	217*	0.10 ⁺	Private – rain, creek, bore Bulk – Potable water from Tenterfield, Urbenville, Kyogle & Stanthorpe
Legume	152	98*	0.04 ⁺	
Liston	133	85*	0.04 ⁺	
Torrington	81	59*	0.02 ⁺	
Mingoola	18	8*	0.01 ⁺	
*Number of private dwellings				
⁺ Based on 282L / person / day from ABS data. It is acknowledged that this is likely higher than actual consumption				

Details of the Shire's critical customers and their water use is provided in Section 3.5.3; Table 3-1.

Non-residential water consumption equates to approximately 33% of the total consumption. The biggest category of water users in this section is accommodation providers (including combined accommodation and restaurant), accounting for 35% of the non-residential water use. This is followed by the medical industry (20%) and Council facilities (14%). Note: Council facilities includes the water and sewer treatment plants, chambers, depots and parks. Service stations and retail both use 6% of the total non-residential water use.

9.3 Water Usage

In the 2018/2019 financial year, residential water demand contributed 67% of the water use in the Shire (Figure 9-1), with Tenterfield using 90% of the total reticulated water in the Shire.

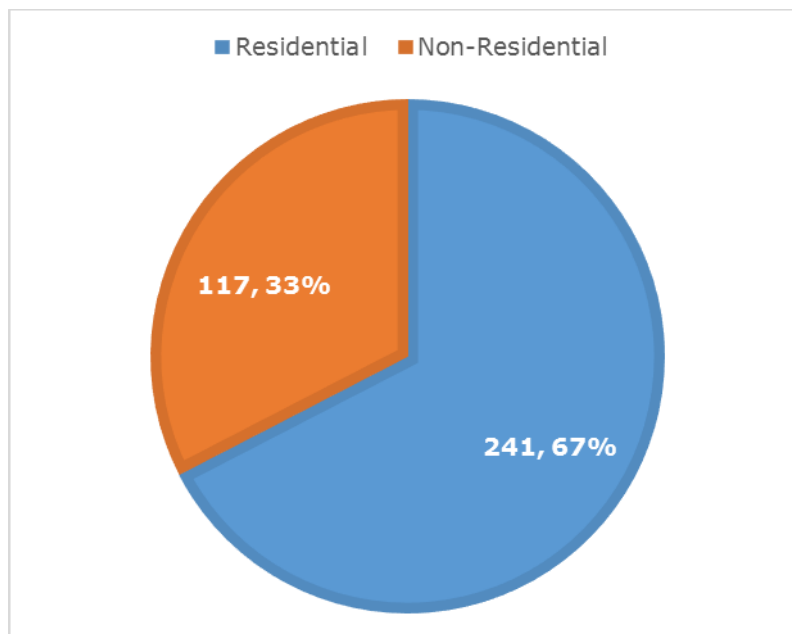

Figure 9-1 Contribution to Water Demand 2018/2019

9.3.1 Tenterfield

Figure 9-2 shows the average daily water consumption (KL) for the Tenterfield township and the dam capacity (%) from 1990 to now (excluding 2006, as this data was corrupt). The overall trend has been towards the town using less water over this period. This is significant, as the ABS Census data shows that there has been a 6% increase in population from 2001 to 2019. There is also a clear correlation between drought conditions and a decrease in water use.

As outlined in Section 6.2.1, the Tenterfield Township is currently using approximately 214L/person/day or 0.87ML/day. During non-drought periods, the average daily consumption for the town is 1.2ML.

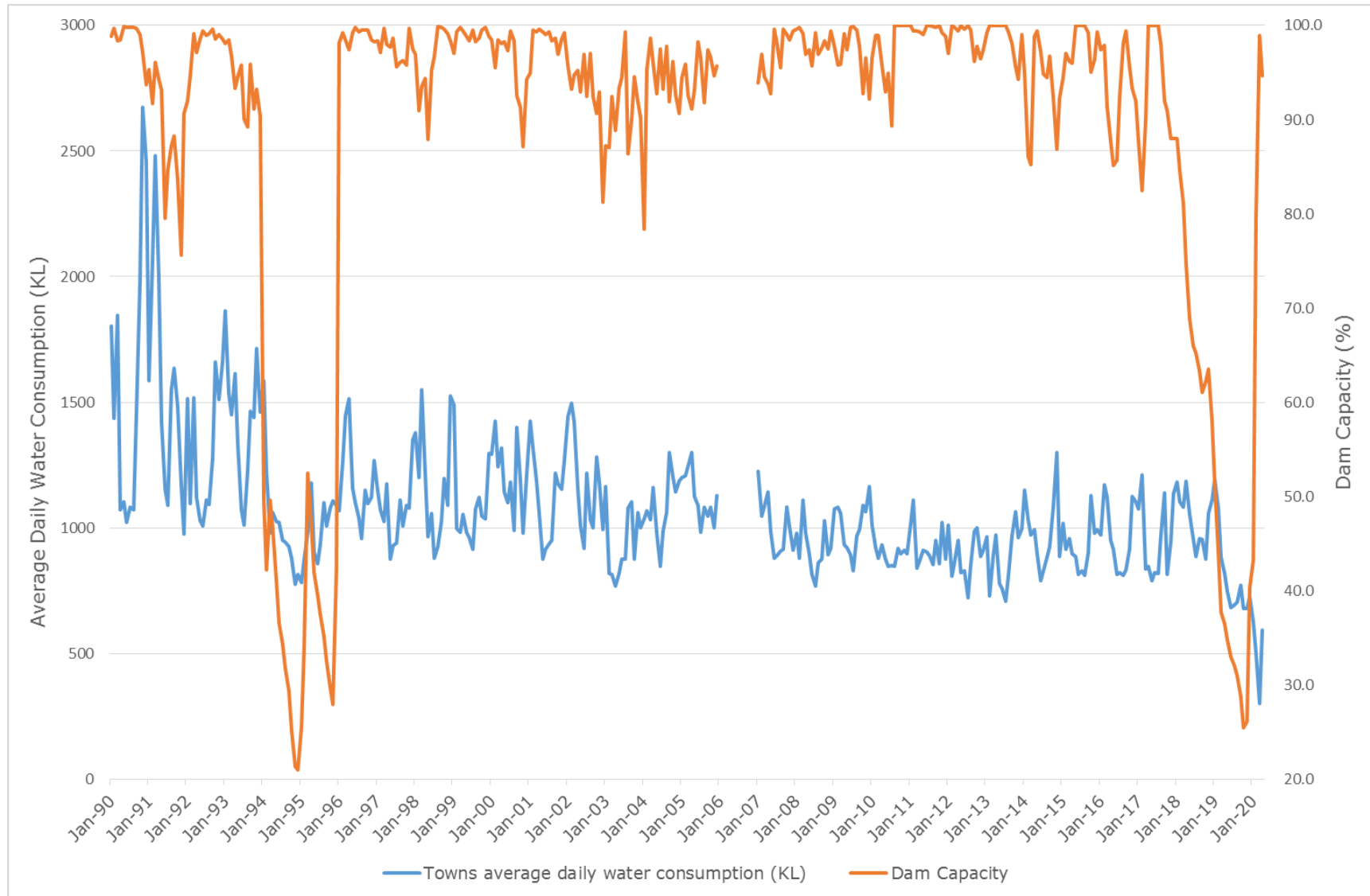

Figure 9-2 Long Term Consumption and Dam Levels for Tenterfield

9.3.2 *Urbenville*

Figure 9-3 shows the average daily water consumption (KL) for the Urbenville water supply network and the creek capacity (%) from 2019 to now. The overall trend has been towards the area typically using less water. However, there is significant seasonal variation in water use. It also shows that there has been some significant water use in 2019-2020. This is possibly due to the fires in the region and an increase in potable water being delivered to rural properties who are usually self-sufficient. It should be noted that Urbenville has tropical climate conditions, which may account for the seasonal variation in water use.

There has been an increase in population from 2001 to 2016. However, the peak population was in 2011, with a decrease in population size from 2011 to 2016.

As outlined in Section 7.2.1, the Urbenville supply network is currently using approximately 304L/person/day or 239KL/day. During non-drought periods, the average daily consumption for the area is 250KL.

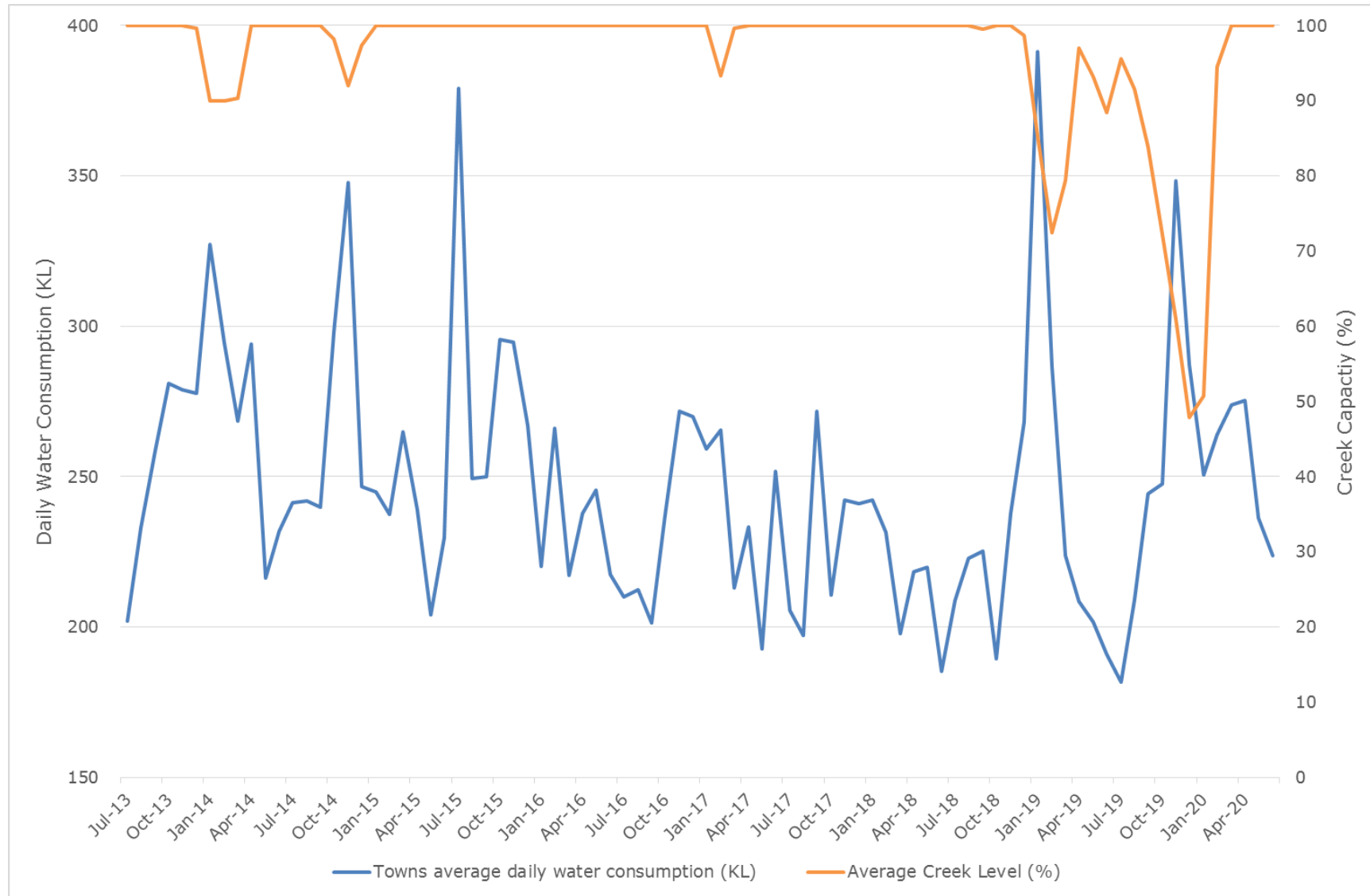

Figure 9-3 Long Term Consumption and Creek Levels for Urbenville

9.3.3 Jennings

Figure 9-4 shows the average weekly consumption (KL) for Jennings from the 2007/2008 financial year to the 2019/2020 financial year. There is no information about the seasonal variation of water use for this area. The water use since the 2014/2015 financial year has been for a decrease in water use. The small peak in the 2018/2019 financial year is likely as a result of the fires in the area.

The population of Jennings is shown to be declining (between 2011 and 2016), according to the ABS Census data.

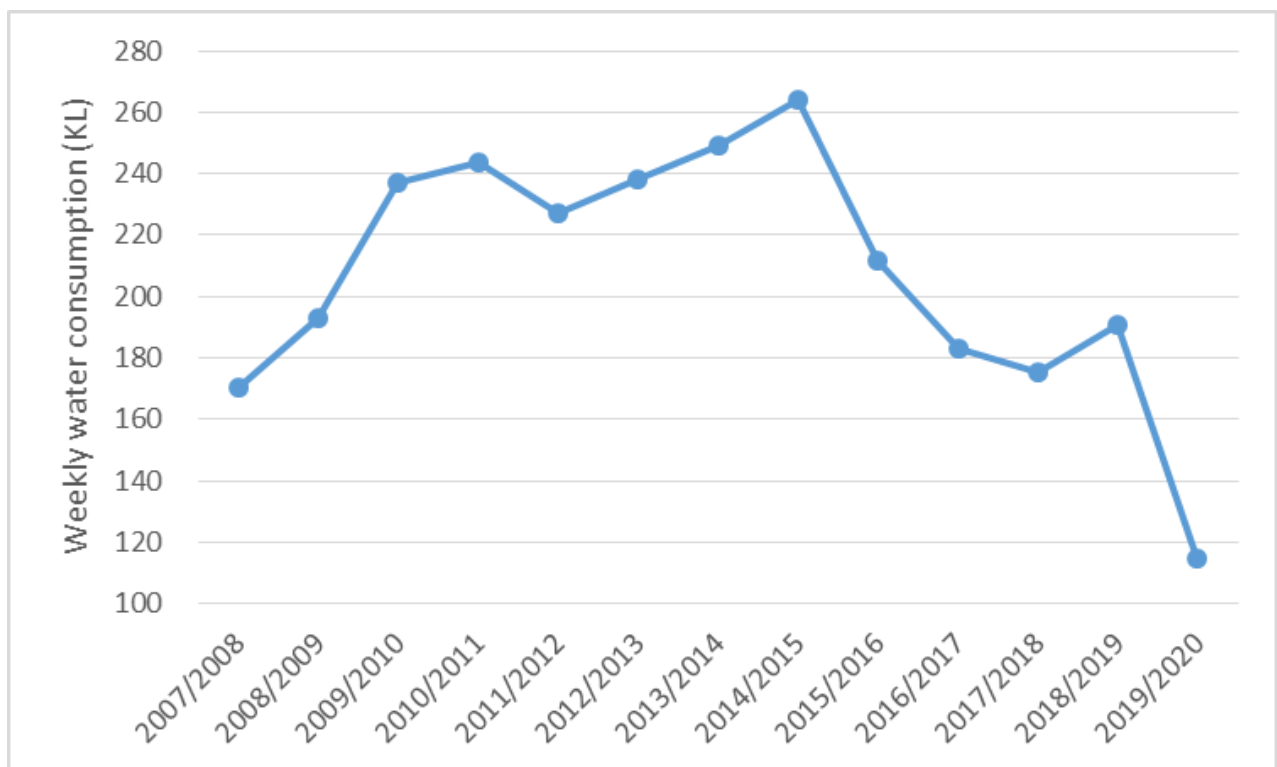

Figure 9-4 Long Term Consumption for Jennings

9.4 Top Water Consumers

Tenterfield Shire Council does not have commercial or industrial water users that are considered significant (using more than 10ML per annum). It should also be noted that the residential sector consumes approximately 70% of the water produced within the Shire (refer to Figure 9-1). Therefore, water savings from the commercial sector have not been focused on in the restrictions, as more impact will be gained from water savings in the residential sector. However, it is

proposed to work with the top (commercial) water users within the Shire to see if any water savings can be achieved.

Figure 9-5 shows the percentage of water use for the top 20 commercial/industrial water users within the Shire, broken into broad categories. For confidentiality reasons, the top 20 water users will not be listed. As is shown below, the Accommodation (including accommodation with attached restaurants) comprise most of the water use through the Shire.

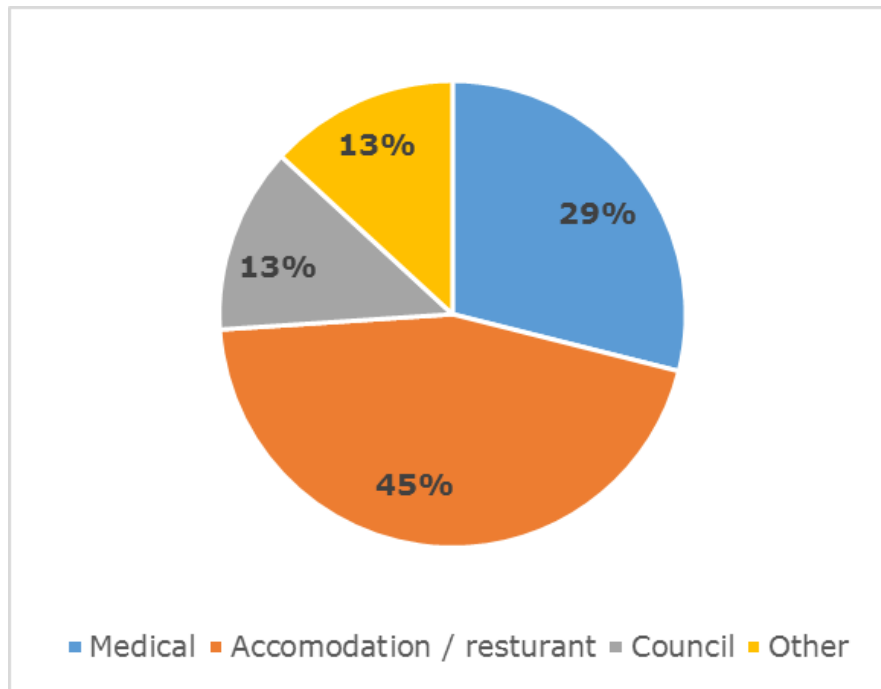

Figure 9-5 Top water users

10 Climate

10.1 Rainfall, Evaporation and Temperature

Evaporation data is not explicitly recorded by BoM in our region. Based on BoM's average pan evaporation maps, evaporation in our region ranges from 200 - 175mm in January and December to 80 - 60mm in May, June and July.

10.1.1 Tenterfield

BoM have a weather station at Tenterfield that has been recording rainfall data since 1870 and temperature data from 1965. Figure 10-1 shows the monthly rainfall and temperature trends for those time periods. As shown, we typically

get our highest rainfall between October and March, with the maximum rainfall typically occurring in January. The temperature ranges from a maximum of 39.9°C (February) to a minimum of -10.6°C (July).

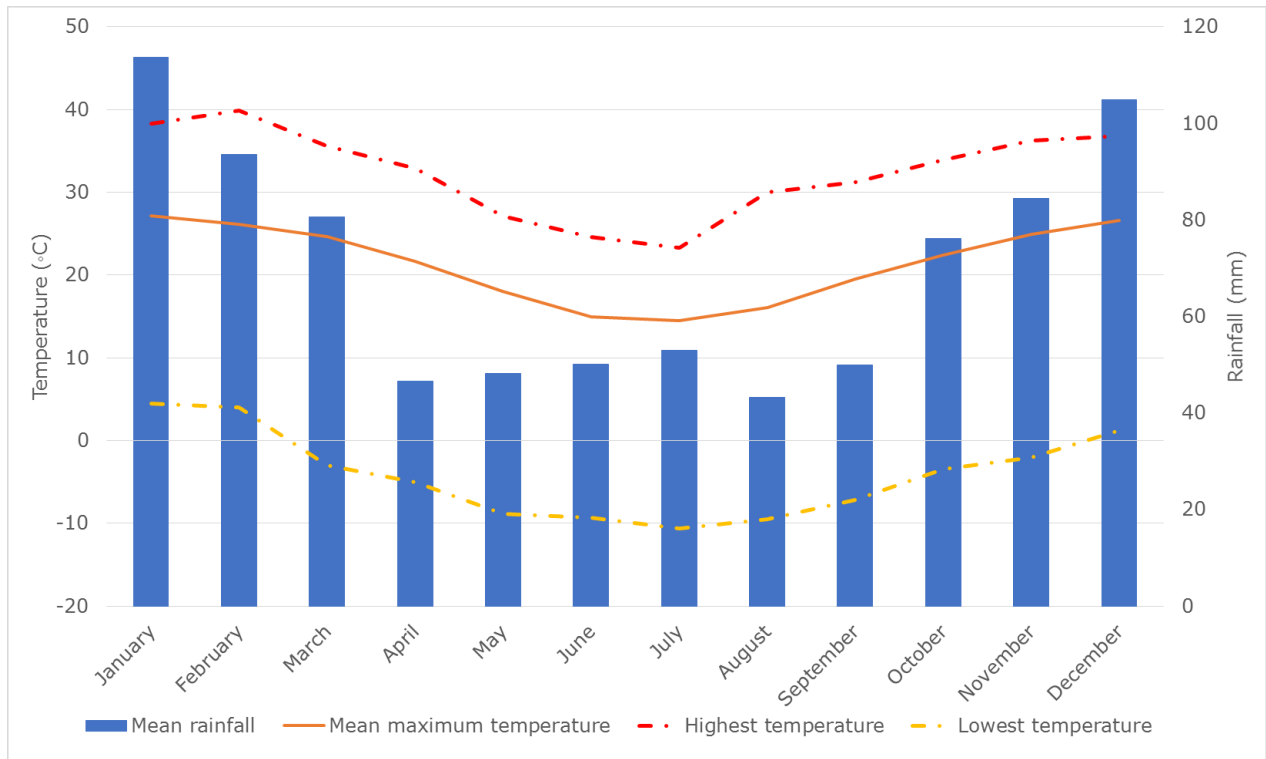

Figure 10-1 Tenterfield Climate Data

10.1.2 Urbenville

The Urbenville Post Office (BoM) gauge records rainfall only, as shown in Figure 10-2. It has been recording rainfall from 1935. It was recording temperature, but only between 1938 and 1961. The highest rainfall occurs between January and March, with another high rainfall period between October to December.

The closest weather station that records temperature as well as rainfall is Warwick (BoM), which is shown in Figure 10-3. Killarney Post Office does have a gauging station, but it stopped recording temperature in 1992. The Warwick rainfall shows a different pattern to Urbenville, with the highest rainfall being between October and December, with another high period between January and March. The temperature ranges from a maximum of 42.2°C (February) to a minimum of -7.7°C (July).

Council have also collected rainfall and maximum/minimum daily temperature from July 2013 to present. The monthly average data is presented in Figure 10-6. As this is a very small dataset, it should be used with caution. The graph shows a similar rainfall trend to Warwick, with higher rainfall during October to December. The temperature ranges from a maximum of 45°C (February) to a minimum of -3°C (June).

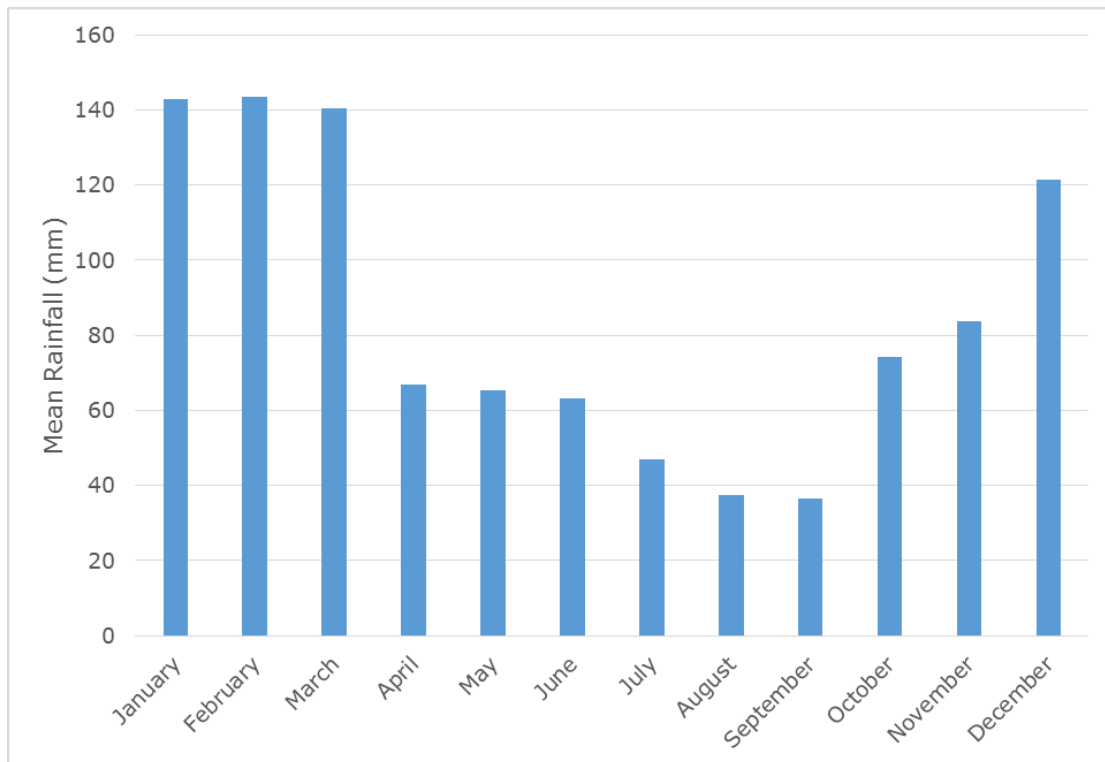

Figure 10-2 Urbenville Rainfall Data

Tenterfield Shire Council - Drought Management Plan

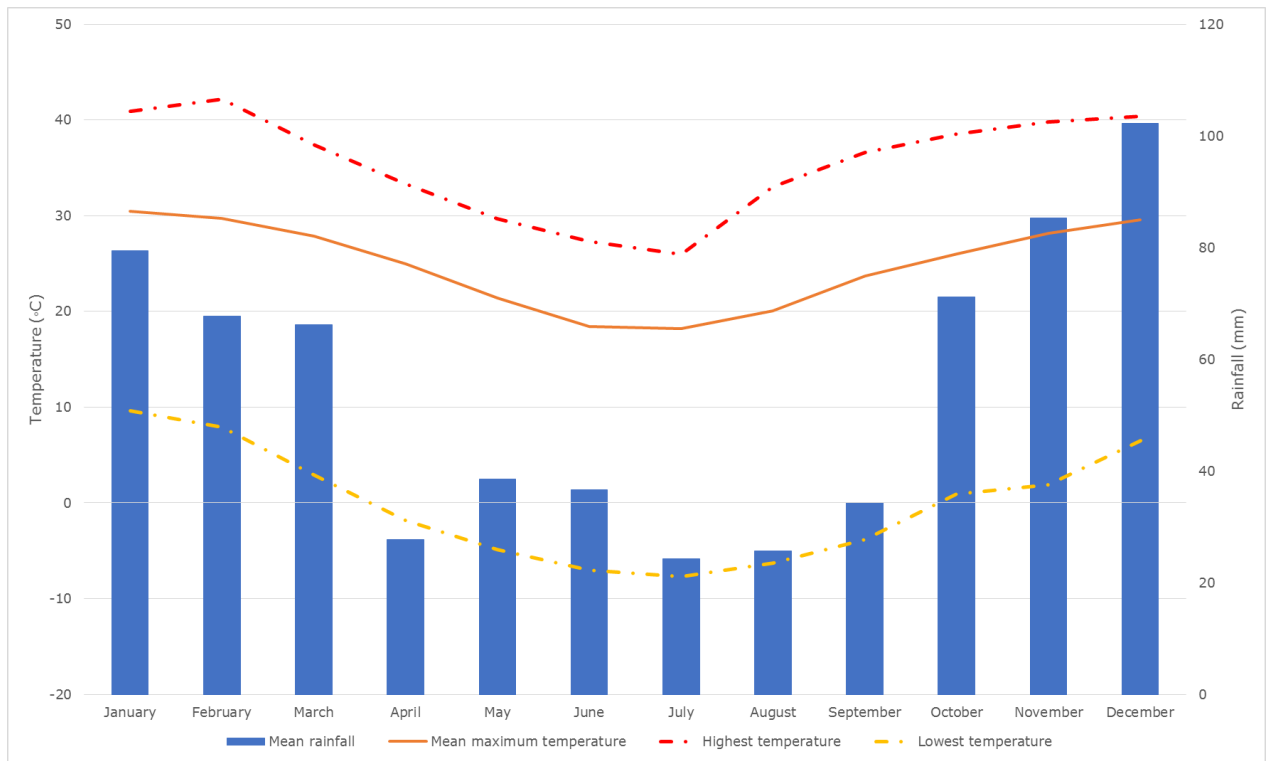

Figure 10-3 Warwick Climate Data

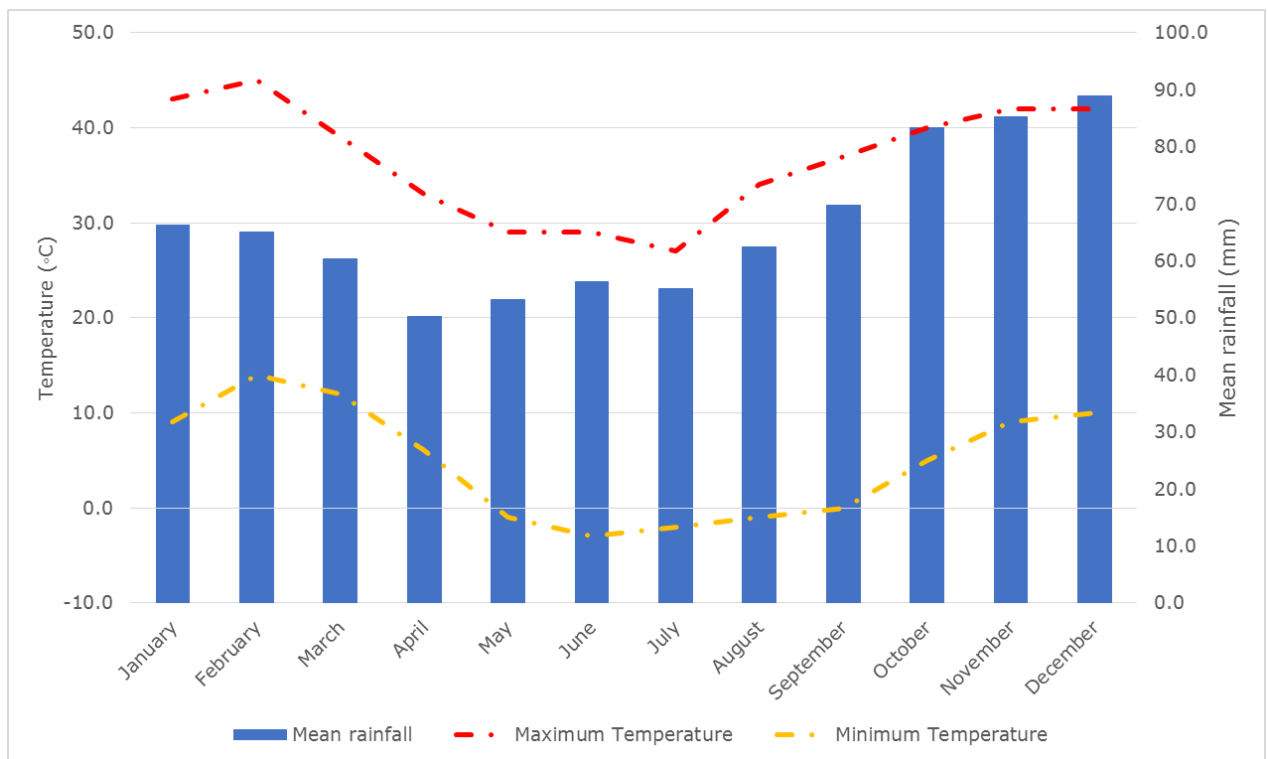

Figure 10-4 Urbenville Climate Data

10.1.3 Jennings

The closest BoM gauge to Jennings is the Wallangarra Post Office, which records rainfall only (it stopped recording temperature in 1992), shown in Figure 10-5. This gauge has rainfall records from 1870. This graph shows that the highest rainfall occurs between October and March.

The closest gauge that records both rainfall and temperature is the Stanthorpe Leslie Parade Gauge (BoM), shown in Figure 10-6. This gauge has rainfall records from 1873 and temperature records from 1938. The Stanthorpe gauges shows a similar rainfall trend to Wallangarra, with the highest rainfall occurring between October and March. The temperature ranges from a maximum of 38°C (December) and -4.2°C (July).

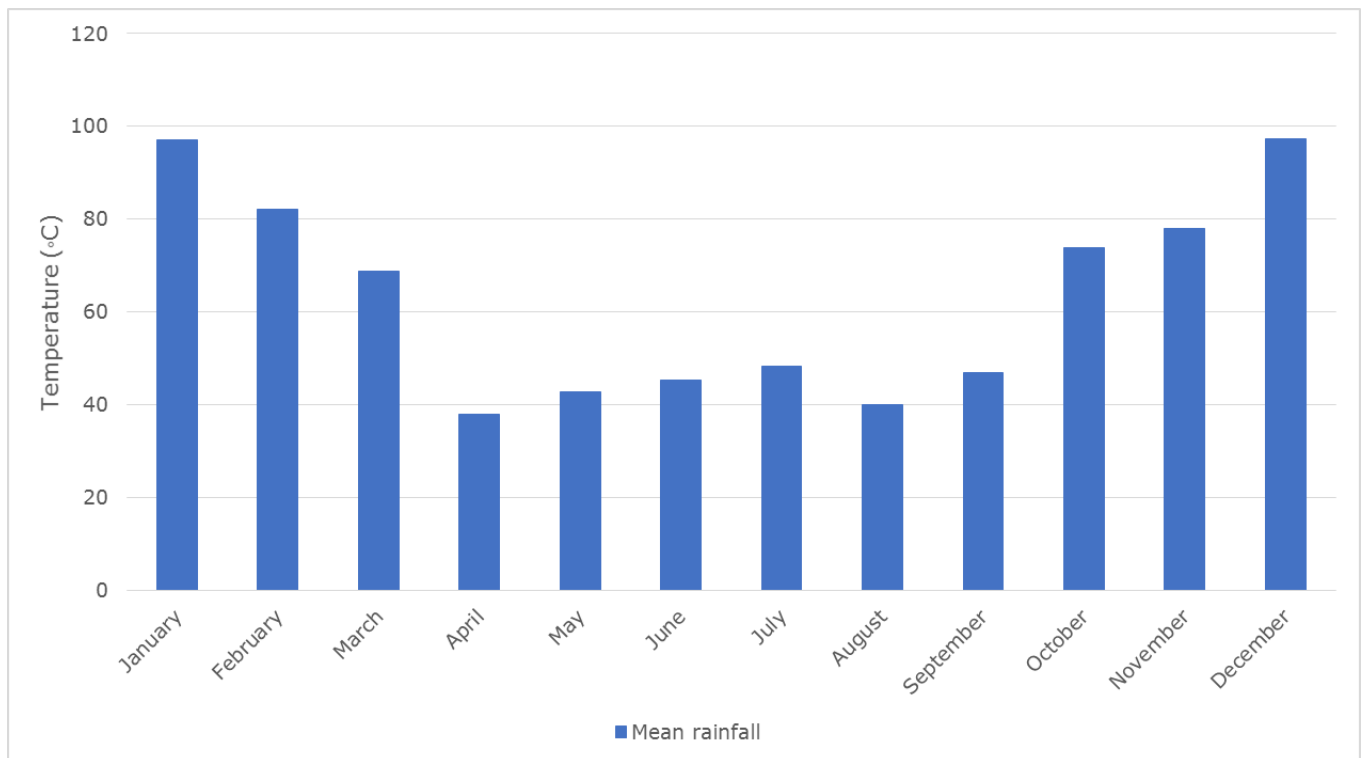

Figure 10-5 Wallangarra Rainfall Data

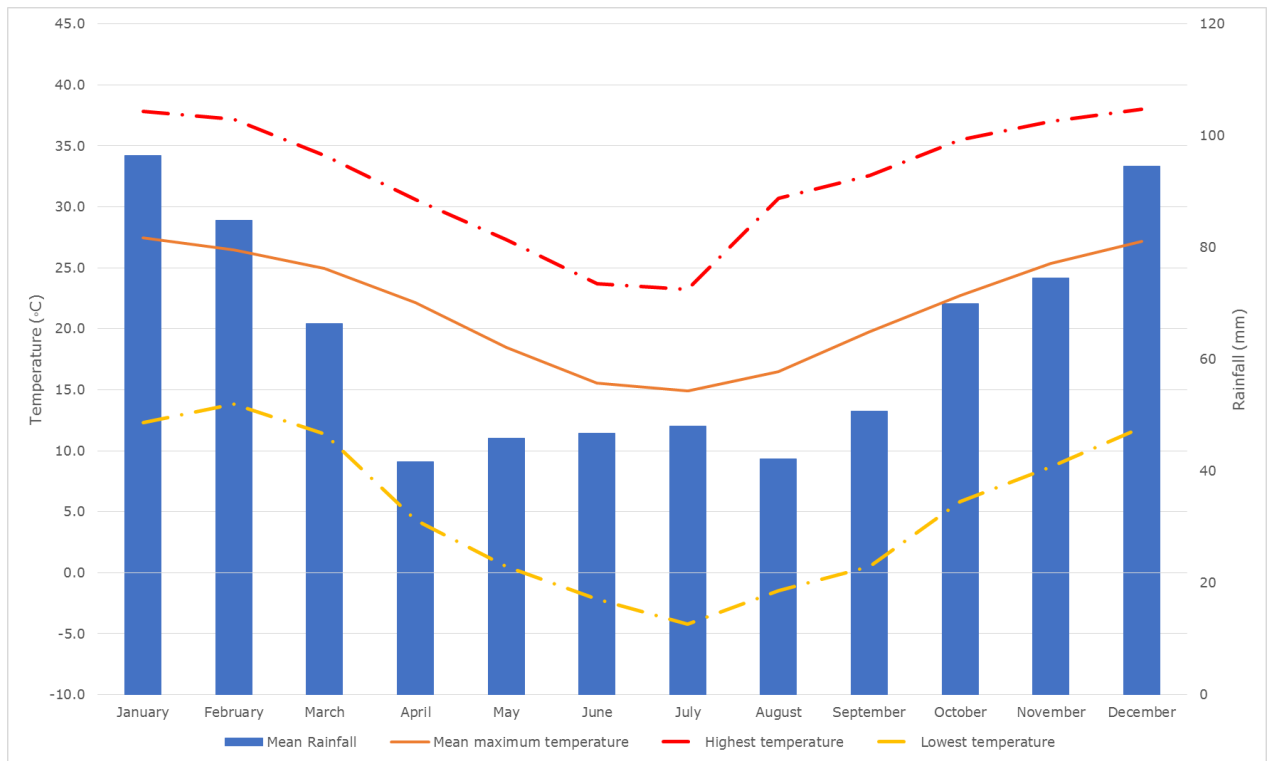

Figure 10-6 Stanthorpe Climate Data

10.2 Drought Restrictions History

As mentioned in Sections 6 - 8, there have been numerous droughts within the Shire. Council have records of water level restrictions going back to 2002, which are outlined in Table 10-1 for Tenterfield, Table 10-2 for Urbenville and Table 10-3 for Jennings. Records of years prior to 2018 are incomplete, and are based on newspaper articles.

Table 10-1 Tenterfield Drought restrictions history

Date Implemented	Restriction Level
25/11/1993	No fixed hoses or sprinklers
27/01/1994	No fixed hoses or sprinklers. Handheld hoses permitted between 6:00am – 8:00am and 6:00pm – 8:00pm
28/02/1994	Level 4 (numbered restriction levels introduced)
31/03/1994	Level 3
19/05/1994	Modified level 3
15/11/1994	Level 5
20/02/1995	Level 2
01/08/2002	Level 1
17/10/2002	Level 2
28/11/2002	Level 3
26/12/2002	Level 4
24/11/2003	Level 3
01/02/2004	Level 1
13/11/2005	Level 2
16/01/2006	Level 1
01/07/2011	Restrictions lifted – permanent water conservation measures
11/04/2018	Level 1
24/09/2018	Level 2
21/01/2019	Level 3
11/02/2019	Level 4
17/04/2019	Level 4.5
29/10/2019	Level 4.7
14/02/2020	Restrictions lifted – permanent water conservation measures
02/03/2020	Level 1

Table 10-2 Urbenville Drought restrictions history

Date Implemented	Restriction Level
24/02/2003	Level 2
07/03/2003	Restrictions lifted
23/12/2003	Level 1
06/05/2007	Level 2
15/07/2007	Level 3
12/08/2007	Level 6
23/09/2007	Level 1
01/07/2011	Restrictions lifted – permanent water conservation measures
28/01/2019	Level 1
04/02/2019	Level 2
09/12/2019	Level 3
10/01/2002	Level 4
24/02/2020	Restrictions lifted
02/03/2020	Level 1

Table 10-3 Jennings Drought restrictions history

Date Implemented	Restriction Level
30/8/1993	Ban on unattended hoses. Use of 1 handheld hose per property anytime. Domestic sprinklers permitted between 7:00am and 9:00am on certain days.
02/12/1993	Ban on unattended hoses. Use of 1 handheld hose per property on specific days. Domestic sprinklers permitted between 6:00pm and 7:00pm on certain days.
13/01/1994	Sprinklers and unattended hoses banned. 1 handheld hose permitted between 6:00am-8:00am and 6:00pm - 8:00pm on certain days.
15/02/1994	Sprinklers and unattended hoses banned. 1 handheld hose permitted between 7:00am-8:00am and 7:00pm - 8:00pm on certain days.
17/03/1994	Unattended hoses banned. 1 handheld hose or domestic sprinkler permitted between 6:00am – 8:00am and 5:00pm – 7:00pm on certain days.
26/05/1994	Unattended hoses banned. 1 handheld hose or domestic sprinkler permitted between 12 noon – 2:00pm
02/02/1995	Sprinklers and unattended hoses banned. 1 handheld hose permitted for 1 hr on certain days
02/03/1995	Sprinklers and unattended hoses banned. 2 handheld hose permitted for 1 hr on certain days
24/10/2002	Increase in restrictions
03/06/2003	1 hand held hose for 1 hour only
23/10/2003	Use of sprinklers and hoses at any time on specified days
20/01/2004	Use of sprinklers and hoses at any time on specified days
04/05/2005	Use of 1 handheld hose anytime on allocated days. Ban on sprinklers and unattended hoses.
12/10/2006	Use of 1 handheld hose between 4pm-5pm on allocated days
12/04/2007	Total ban on use of hoses or sprinklers anytime
30/04/2007	Total ban on outside use of mains water
10/01/2008	Use of 1 handheld hose anytime on allocated days
07/05/2008	Use of 1 handheld hose between 4pm-5pm on allocated days
13/06/2019	Medium
01/08/2019	Critical
19/12/2019	Emergency
24/02/2020	Critical
19/03/2020	Extreme

10.3 *Effects of Restrictions on Water Demand*

Figure 10-7 below shows Tenterfield's response to the 2002 drought. This graph shows that water consumption typically decreased as a result of the introduction of water restrictions. It also shows that average water use does have a tendency to increase again once the restrictions have been in place for about a month. This is despite the fact that the current restriction levels were advertised fortnightly in the local newspapers and on the radio.

Figure 6-5 shows Tenterfield's response to the 2018 drought. This graph shows that typically there is a decrease in water usage as a result of the introduction of water restrictions. After a few months of restrictions, we do tend to see an increase in water usage. There is a small increase in water consumption around September 2019, but can be attributed to the bush fires that were threatening the town.

Figure 7-3 shows Urbenville's response to the 2008 drought. Urbenville was not under drought conditions for long, but a similar trend was observed, where there was reduction in water consumption for a month after the introduction of water restrictions, followed by an increase.

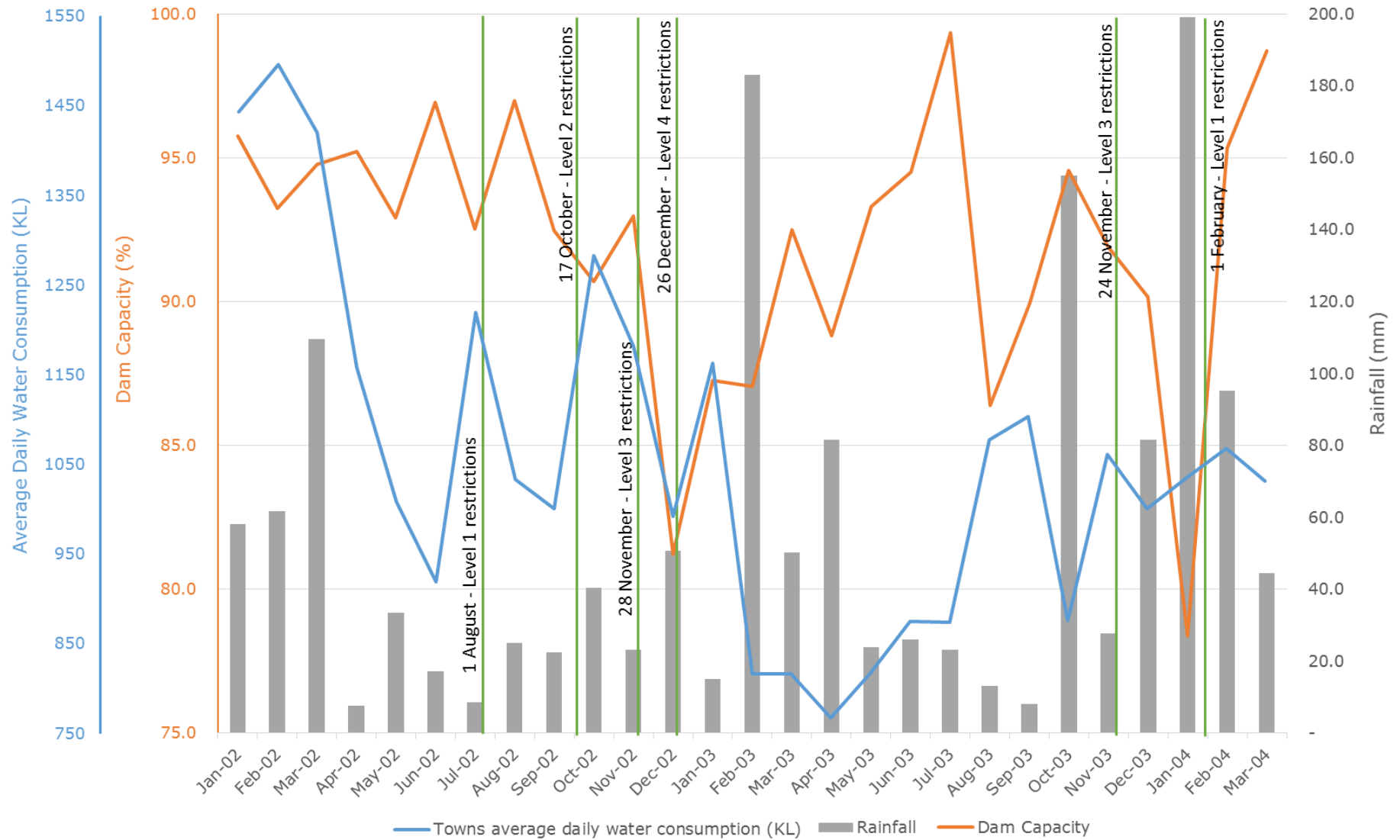

Figure 10-7 Tenterfield’s response to water restrictions 2002-2004

10.4 Supply-Side Historical Actions

10.4.1 Tenterfield

As part of the emergency measures undertaken for the 1994 drought, Council undertook a bore investigation. This resulted in 1 production bore: Shirley Park and 1 livestock bore: Apex Park. The Shirley Park Bore was connected directly into the Tenterfield Dam. Apex Park Bore was capped.

In 2003 Council petitioned the State Government for the Shire to be included in the rainwater tank rebate program. This was unsuccessful until 2007/2008, when Council in conjunction with the State Government, were able to offer a rainwater tank rebate.

In the most recent drought, the following actions were undertaken:

- sediment around the edge of the dam were excavated
- a survey of the bathymetry of the dam to get a revised estimate of dam capacity
- new bores were installed making a secondary bore field supply
- water quality improvements in the dam, including improved monitoring and an aeration system.

10.4.2 Urbenville

During the 2007 drought, Council received funding from the State Government to extend and improve the offtake pipe and dredge the creek. This allowed Council to reach lower levels in the weir pool to supply water from.

During the recent drought, Council sought to get funding for an off-stream storage and to undertake a bore investigation. We were not successful for funding and will continue to seek funding for these improvements.

11 Regulatory Framework

11.1 *Local Water Utility*

Council delivers water under the provisions of the NSW Local Government Act 1993. Some aspects of the water business are carried out under provisions under the NSW Water Management Act 2000. Council is empowered to restrict water supply (e.g. by public notice published in a newspaper circulating within Council area) under the Local Government (General) Regulation 2005.

The Local Government Act 1993 Section 637 read: "a person who wilfully or negligently wastes or misuses water from a public water supply, or causes any such water to be wasted, is guilty of an offence". The maximum penalty which can apply is:

- Maximum penalty: 20 penalty units
- Current (as per 1 July 2020) penalty unit: \$133.45

Consumers who are identified breaching water restrictions in place may have their supply restricted by Council in accordance with Clause 144 of the Local Government (General) Regulation 2005.

This plan is administered by Council. During drought, this plan will be overseen by the Drought Management Team (see Section 4.2). The implementation of this Drought Management Plan will be the responsibility of the Drought Incident Manager.

11.2 *DPIE Water*

11.2.1 *General*

Department of Planning, Infrastructure and Environment (DPIE) Water works with partner agencies and the community to provide a reliable, sustainable supply of water for households, irrigators, farmers, industry and the environment.

Available water determinations are made for each water source generally at the start of a water year (on 1 July). The licenced volume or the percentage of the share component is defined by DPIE Water. Since the introduction of the Water

Management Act 2000, DPIE Water has prepared water sharing plans for rivers and groundwater systems across NSW.

11.2.2 Water Sharing Plans

By setting the rules for how water is allocated for the next 10 years, a water sharing plan provides a decade of security for the environment and water users. This not only ensures that water is specifically provided for the environment through a legally binding plan, but also allows licence holders, such as irrigators, who require large volumes of water, to plan their business activities.

11.3 Fire Fighting Requirements

In spite of water restriction actions, preference will be provided to accommodating firefighting requirements.

In the event that the emergency (level 5 restrictions) conditions last for more than 3 days, fire services will be directed to arrange alternate water source (e.g. water tankers) if appropriate. Council will work with the relevant Fire Departments to ensure adequate fire-fighting supply.

Note: at the time of writing, more information about the fire-fighting requirements for the RFS was not available. More information is being sought through the RFS and will be updated when available.

Appendix A. SDRC Water Restrictions

Table 11-1 SDRC Water Use Targets

Restriction Level	Water Use Target
Permanent	230 L/person/day
Medium	200 L/person/day
High	170 L/person/day
Extreme	120 L/person/day
Critical	100 L/person/day
Emergency Target	80 L/person/day

Table 11-2 SDRC Water Restrictions - High

Outdoor Use activity	Allowed any time	Allowed on allocated days and times
High		
Sprinklers & fixed irrigation systems	✘	✘
Hand held hosing of gardens and laws	✘	✓ (lawn not allowed)
Garden water using buckets	✘	✓
Washing vehicles with a trigger hose or bucket	✘	✓ (on grassed area only)
Cleaning vehicle windows, mirrors or lights using a bucket	✓	✓
Topping up fountains, ponds, pools or spas	✘	✘
Cleaning paved areas using a bucket or high pressure water unit	✘	✘ (exceptions for health or safety reasons only)
Cleaning building using a trigger hose or high pressure water unit	✘	✘
Cleaning windows with a bucket	✘	✓

Odd house number or no numbers: odd number calendar date

Even house numbers: even number calendar date

Outdoor water use times: May to September: allocated days 5pm-6pm

October to April: allocated day 6pm-7pm

The following tables are applied to Extreme, Critical and Emergency Restriction Levels. Water restrictions apply to residents who access drinking water supplied by Southern Downs Regional Council. This includes those accessing the town water supply via a reticulated system or rural residents who purchase water supplied via the bulk water supply standpipes.

The tables below offer additional guidance for residents, commercial operators and community groups. Penalties may apply for non-compliance.

Table 11-3 SDRC Conditional Use: Water Restrictions - Residential

RESIDENTIAL WATER USE ACTIVITY	CONDITIONS APPLY Note: Any water used for these purposes forms part of an individual's daily water allowance
General outdoor cleaning (includes: solar panels, buildings, landscaping, entertainment areas, outdoor furniture and paved surfaces)	General outdoor cleaning for health and safety only is permitted at any time using water efficient measures. Use of drinking water is not permitted to remove loose items that could be easily removed by a broom, blower or similar device.
Cleaning of residential vehicles (cars, boats, caravans, trailers and bikes)	Drinking water may be used from a bucket filled directly from a tap to: (1) spot clean a surface to remove potentially paint damaging marks; (2) clean only vehicle mirrors, vehicle lights, glass and number plates to maintain safe operation and visibility requirements; (3) clean other such parts of a vehicle as required to comply with statutory or regulatory obligations or (4) to flush an inboard or outboard motor or vehicle brakes to prevent corrosion and maintain safe operation.
Cleaning of rubbish bins, tools and related equipment as well as animal enclosures/kennels	Cleaning for health and safety is permitted at any time using water efficient measures.
Ornamental fish ponds, frog ponds and outdoor aquariums	Drinking water may be used only if it is collected in a bucket filled directly from a tap and is requirement for the health and safety of the fish, frogs and other aquarium life. Measures must be taken to reduce evaporation where possible.
Building construction – exposed aggregate driveways, laying of turf	Use of drinking water is not permitted.
Building construction - brick laying, tile cutting etc.	Alternative water sources can be used as appropriate.
Cleaning when vacating a rental property	Drinking water is permitted to be used for building construction where: (1) the site is attended; (2) hoses and equipment are in good order with no leaks and (3) water is not running to waste.
General renovations & property maintenance e.g. timber decks, driveways, pathways, house and roof painting preparation	Drinking water may be used for internal house cleaning activities that are required prior to vacating a rental property. External cleaning (windows, outdoor areas) can only be done using a bucket filled from a tap. Use of drinking water is not permitted to remove loose items that could be easily removed by a broom, blower or similar device such as dust and cobwebs.
Topping up of swimming pools	Use of drinking water is not permitted. Alternative water sources can be used as appropriate.

Table 11-4 SDRC Conditional Use: Water Restrictions - Commercial

COMMERCIAL WATER USE ACTIVITY		CONDITIONS APPLY	
		Note: Businesses are expected to reduce their water consumption by an additional 10%	
Cleaning of commercial vehicles (cars, boats, caravans, trailers, bikes, buses and trucks)		Drinking water may be used from a bucket filled directly from a tap to: (1) spot clean a surface to remove potentially paint damaging marks; (2) clean only vehicle mirrors, vehicle lights, glass and number plates to maintain safe operation and visibility requirements; (3) clean other such parts of a vehicle as required to comply with statutory or regulatory obligations or (4) to flush an inboard or outboard motor or vehicle brakes to prevent corrosion and maintain safe operation.	
Cleaning of rubbish bins, tools and related equipment as well as animal enclosures/kennels		Cleaning for health and safety only is permitted at any time using water efficient measures.	
Building Construction – dust suppression		Use of drinking water is not permitted for dust suppression on construction sites.	
Building Construction (brick laying, tile cutting etc.)		Drinking water is permitted to be used for building construction where: (1) the site is attended; (2) hoses and equipment are in good order with no leaks and (3) water is not running to waste.	
Ornamental fountains		Use of drinking water is not permitted. Alternative water sources can be used as appropriate.	
Council and state government parks and road reserves		Use of drinking water is not permitted. Alternative water sources can be used as appropriate.	
Active playing surface irrigation		Use of drinking water is not permitted. Alternative water sources can be used as appropriate.	
Topping up of swimming pools		Use of drinking water is not permitted.	

Table 11-5 SDRC Conditional Use: Water Restrictions - Community

COMMUNITY GROUP WATER USE ACTIVITY		CONDITIONS APPLY	
		Note: Groups must upgrade facilities where possible using waterwise products and actively display waterwise information in canteens and bathrooms.	
Community group clubhouses and facilities – general cleaning		Cleaning for health and safety only is permitted at any time using water efficient measures.	
Cleaning of rubbish bins, tools and related equipment		Cleaning for health and safety only is permitted at any time using water efficient measures.	
When hosting events		Use of drinking water is permitted for domestic use only. Drinking water is not to be used for: <ul style="list-style-type: none"> • Washing down of vehicles or animals • the cleaning of storage areas or animal pens 	
Ornamental fountains		Use of drinking water is not permitted. Alternative water sources can be used as appropriate.	
Maintenance of grounds		Use of drinking water is not permitted. Alternative water sources can be used as appropriate.	
Active playing surface irrigation		Use of drinking water is not permitted. Alternative water sources can be used as appropriate.	

Appendix B. Water Exemption Application Form

The form below is to be used to apply for a water use exemption.

Forms can be emailed to council@tenterfield.nsw.gov.au, posted to PO Box 214, Tenterfield, NSW, 2372, or returned in person to Council's Administration Centre.

Please note that watering during the hottest part of the day (middle of the day) will *NOT* be permitted under any circumstance.

Exemptions will expire when a certain water restriction level is reached, which will be outlined on your permit.

Submitting a permit does not guarantee approval. Permits can take up to 10 working days for approval.



Water Restriction Exemption Request Form

Please note: watering of gardens will *NOT* be permitted under any circumstances in the middle of the day.

Customer/ Business		
Property address		
Contact phone numbers	B:	M:
Email address		

Category of restriction to which the permit request applies (tick ONE box only)	
<input type="checkbox"/> Private Gardens <input type="checkbox"/> Public Gardens <input type="checkbox"/> Ponds and Lakes <input type="checkbox"/> Fountains <input type="checkbox"/> Cleaning Windows/ Building Roofs <input type="checkbox"/> Farm Dams <input type="checkbox"/> Swimming Pools <input type="checkbox"/> Cleaning Paved Areas	<input type="checkbox"/> Construction Activities <input type="checkbox"/> Sports Grounds / Recreation Areas <input type="checkbox"/> Retail / Wholesale / Market Gardens <input type="checkbox"/> Nursery <input type="checkbox"/> Vehicles, Boats or Aircraft <input type="checkbox"/> Other (please list)

Exemption request details		
Time:	Days:	Dates:

Reason of which exemption should be granted	
<input type="checkbox"/> Adverse financial impact <input type="checkbox"/> Request results in less water being used <input type="checkbox"/> Special needs	<input type="checkbox"/> Physical damage to a building or structure <input type="checkbox"/> Public health or safety <input type="checkbox"/> Filling swimming pool or spa

Please indicate the expected volumes of water required and details of how water will be used

Please indicate the measures in place to reduce the amount of water that will be used

Applicant Declaration

I/we agree to:

- Authorise Tenterfield Shire Council (Council) to publically disclose any relevant details of the permit;
- Adhere to ALL the specific requirements contained within the permit;
- Provide appropriate access to enable Council to assess adherence to the permit conditions;
- Complete all sections of this form;
- Acknowledge that the exemption, if approved, is not transferable to any other party or location and is the responsibility of the permit holder;
- Ensure that every effort will be made to conserve water at all times;
- The permit is relevant only to the current water restriction level. Upon increase of water restrictions, this permit will be void unless otherwise stated within the approval;
- Any violation of the terms of the permit will result in the immediate disqualification of the permit.

Signature of Applicant	
Date	

Forms can be emailed to council@tenterfield.nsw.gov.au, posted to PO Box 214, Tenterfield, NSW, 2372, or returned in person to Council's Administration Centre.

Office use only

Date form received	
--------------------	--

Exemption Request: Approved Denied

Reason for decision	
Permit Number	
Date of commencement	
Date of expiry	
Water restriction level permit expires at	
Name of Authorising Officer	
Signature of authorising officer	
Date	

Appendix C. Water Carters Registration Form

During times of drought, any water carters taking potable water from Council's standpipes need to be registered.

Once approved, access to Council's standpipes will be granted, either in Tenterfield, Urbenville or both.

Water carters are expected to keep records of date, volume of water taken, property that water is being supplied to and intended use. Council can ask to see these records at any time. Once Level 3 water restrictions are reached, water can only be taken for filling of domestic tanks.

Water taken from Council's dispensers can only be supplied to properties within the Tenterfield Shire Council Local Government Boundary, unless specific approval is granted in writing from Council.



Water Carter Registration Form

Business name:		
ABN		
Proprietor/s		
Business/office address		
Mailing address (if different from above)		
Contact phone numbers	B:	M:
Email address		
Is your business registered with the Australian Charities and Not-for-profits Commission?		
<input type="checkbox"/> Yes <input type="checkbox"/> No		

Legislative Requirements		
<i>Requirements</i>	<i>Documents Required</i>	<i>Document Attached</i>
Quality Assurance Program has been developed and submitted to NSW Health to meet the requirements of NSW Water Carters Guidelines	Yes	
The vehicle(s) are fitted with a backflow prevention device or registered air gap that complies with the Plumbing Code of Australia	Yes	
The device or air gap has been tested in the past 12 months by a qualified person	Yes	
The vehicle has public liability insurance for not less than \$20 million dollars indemnifying Tenterfield Shire Council against any claims that may arise from the operation of the water carter business	Yes	

Vehicle(s) Information	
Number of vehicles used for carting	
Registration number of above vehicles	
Tanker dimensions	
Tanker Volume	
Location of where water is drawn	
<input type="checkbox"/> Tenterfield <input type="checkbox"/> Urbenville	

Applicant Declaration

I/we agree to:

- Authorise Tenterfield Shire Council (Council) to publically disclose any relevant details of the permit;
- Complete all sections of this form;
- Ensure that every effort will be made to conserve water at all times;
- Confirm that records will be kept of date, volumes taken and delivery address. Council may request this data at any time;
- Confirm that water taken from Councils' dispensers will be delivered to properties within the Tenterfield Shire Local Government Boundary only;
- Confirm that water taken from Councils' dispensers will be supplied for domestic use only (no filling of dams);
- When the dispenser key is issued, confirm that it will be used for the vehicles registered above only. The key cannot be loaned to other vehicles or companies. Failure to comply with this will result in the key being returned and removal from the Council's registered water carter list;

Signature of Applicant	
Date	

Forms can be emailed to council@tenterfield.nsw.gov.au, posted to PO Box 214, Tenterfield, NSW, 2372, or returned in person to Council's Administration Centre.

Office use only

Date form received	
--------------------	--

Registration Request: Approved Denied

Reason for decision	
Registration Number	
Date of commencement	
Date of expiry	
Name of Authorising Officer	
Signature of authorising officer	
Date	

Appendix D. Waterwise Checklist

The Waterwise checklist is a two page document – page 1 focuses on identifying where immediate water savings can be made and page 2 focuses on identifying how additional water savings can be made in the future.



Be Waterwise

Reduce the Use

WATER CHECKLIST: Review your water conservation practices and plan ahead

Water conservation tips for your workplace or community facility	We do this now	We will review	N/A	Need to follow-up
ACTIONS – What can I do now?				
General review				
Check water meters are working properly and monitor use	<input type="radio"/>	<input type="radio"/>	<input type="radio"/>	<input type="radio"/>
Install signage to encourage water conservation	<input type="radio"/>	<input type="radio"/>	<input type="radio"/>	<input type="radio"/>
Ensure fire water hoses are not used for general activities	<input type="radio"/>	<input type="radio"/>	<input type="radio"/>	<input type="radio"/>
Amenity areas				
Check toilet cisterns for leaks and repair as required	<input type="radio"/>	<input type="radio"/>	<input type="radio"/>	<input type="radio"/>
Use cistern weights to reduce volume in single flush toilets	<input type="radio"/>	<input type="radio"/>	<input type="radio"/>	<input type="radio"/>
Adjust timings and volumes of automatic flush urinals	<input type="radio"/>	<input type="radio"/>	<input type="radio"/>	<input type="radio"/>
Install tap aerators or tap flow control valves	<input type="radio"/>	<input type="radio"/>	<input type="radio"/>	<input type="radio"/>
Install water efficient showerheads or shower control valves	<input type="radio"/>	<input type="radio"/>	<input type="radio"/>	<input type="radio"/>
Heating and cooling systems				
Turn off air conditioner cooling systems when not required	<input type="radio"/>	<input type="radio"/>	<input type="radio"/>	<input type="radio"/>
Check blowdown/bleed-off control on boilers and cooling towers	<input type="radio"/>	<input type="radio"/>	<input type="radio"/>	<input type="radio"/>
Increase concentration cycles for air conditioning cooling towers	<input type="radio"/>	<input type="radio"/>	<input type="radio"/>	<input type="radio"/>
Check the seal and float valve unit for wear. Review settings.	<input type="radio"/>	<input type="radio"/>	<input type="radio"/>	<input type="radio"/>
Check the cooling system pump for leaks	<input type="radio"/>	<input type="radio"/>	<input type="radio"/>	<input type="radio"/>
Outdoor water use				
Install signage to increase awareness of water restrictions	<input type="radio"/>	<input type="radio"/>	<input type="radio"/>	<input type="radio"/>
Inspect, repair or replace any leaking pipes and outdoor taps	<input type="radio"/>	<input type="radio"/>	<input type="radio"/>	<input type="radio"/>
Sweep or use garden blowers on paved areas instead of hosing (<i>unless required to meet occupational health and safety standards</i>)	<input type="radio"/>	<input type="radio"/>	<input type="radio"/>	<input type="radio"/>
Attach trigger nozzles to all hoses (<i>permissible uses only</i>)	<input type="radio"/>	<input type="radio"/>	<input type="radio"/>	<input type="radio"/>
Use high pressure cleaning units in place of hoses (<i>permissible uses only</i>)	<input type="radio"/>	<input type="radio"/>	<input type="radio"/>	<input type="radio"/>
Review options to meet plant water needs when maintaining gardens	<input type="radio"/>	<input type="radio"/>	<input type="radio"/>	<input type="radio"/>
Use mulch around ground covers, trees and shrubs	<input type="radio"/>	<input type="radio"/>	<input type="radio"/>	<input type="radio"/>
Adjust times for automatic irrigation equipment (e.g. sporting fields). Turn off timers when water is not required	<input type="radio"/>	<input type="radio"/>	<input type="radio"/>	<input type="radio"/>
Ensure hard surfaces are not being watered	<input type="radio"/>	<input type="radio"/>	<input type="radio"/>	<input type="radio"/>
Pool and spa areas				
Use a pool cover to reduce water loss due to evaporation	<input type="radio"/>	<input type="radio"/>	<input type="radio"/>	<input type="radio"/>
Check for and repair any leaks	<input type="radio"/>	<input type="radio"/>	<input type="radio"/>	<input type="radio"/>
Check the filter backwash schedule and adjust if possible	<input type="radio"/>	<input type="radio"/>	<input type="radio"/>	<input type="radio"/>
Keep heated pools to a minimum temp to reduce evaporation	<input type="radio"/>	<input type="radio"/>	<input type="radio"/>	<input type="radio"/>
Vehicle washing				
Limit the number of spray nozzles, their flow rate and pressure	<input type="radio"/>	<input type="radio"/>	<input type="radio"/>	<input type="radio"/>
Place timers and shut-off valves on vehicle washers	<input type="radio"/>	<input type="radio"/>	<input type="radio"/>	<input type="radio"/>
Use rainwater to wash vehicles where required	<input type="radio"/>	<input type="radio"/>	<input type="radio"/>	<input type="radio"/>



Be Waterwise

Reduce the Use

Water conservation tips for your workplace or community facility	We do this now	We report to staff	N/A	Listed in asset register
How can I plan for the future?				
General review				
Schedule daily or weekly water meter reads and share information with staff and management to monitor trends	<input type="radio"/>	<input type="radio"/>	<input type="radio"/>	<input type="radio"/>
Maintain signage to encourage water conservation (e.g. <i>turn off the tap</i>)	<input type="radio"/>	<input type="radio"/>	<input type="radio"/>	<input type="radio"/>
Schedule fire water hose testing dates	<input type="radio"/>	<input type="radio"/>	<input type="radio"/>	<input type="radio"/>
Develop a roster for checking leaks and undertaking repairs	<input type="radio"/>	<input type="radio"/>	<input type="radio"/>	<input type="radio"/>
Gauge interest in staff being “water champions” to assist water monitoring and sharing of information	<input type="radio"/>	<input type="radio"/>	<input type="radio"/>	<input type="radio"/>
Amenity areas				
Install sensor activated taps where appropriate	<input type="radio"/>	<input type="radio"/>	<input type="radio"/>	<input type="radio"/>
Retrofit toilet cisterns with more water efficient models	<input type="radio"/>	<input type="radio"/>	<input type="radio"/>	<input type="radio"/>
Review capacity to collect rainwater for the purpose of toilet flushing	<input type="radio"/>	<input type="radio"/>	<input type="radio"/>	<input type="radio"/>
Replace automatic flush urinals and low flush valve operated urinals, waterless urinals or manual operated urinals	<input type="radio"/>	<input type="radio"/>	<input type="radio"/>	<input type="radio"/>
Schedule appliance replacement e.g. dishwashers and washing machines and identify best products using the Water Efficiency Labelling Scheme (WELS)	<input type="radio"/>	<input type="radio"/>	<input type="radio"/>	<input type="radio"/>
Heating and cooling systems				
Investigate recycling water flow to cooling tower or replacing with air-cooled equipment to eliminate ‘once through’ cooling of equipment processes	<input type="radio"/>	<input type="radio"/>	<input type="radio"/>	<input type="radio"/>
Insulate water pipes to reduce water use while waiting for it to heat up	<input type="radio"/>	<input type="radio"/>	<input type="radio"/>	<input type="radio"/>
Schedule regular inspections of cooling system pumps and seals	<input type="radio"/>	<input type="radio"/>	<input type="radio"/>	<input type="radio"/>
Outdoor water use				
Install automatic shut-off valves on manual hoses	<input type="radio"/>	<input type="radio"/>	<input type="radio"/>	<input type="radio"/>
Collect rainwater and water from cooling tower bleed-off for re-use on landscaping	<input type="radio"/>	<input type="radio"/>	<input type="radio"/>	<input type="radio"/>
Review garden design and layout – group plants with similar water needs, and reduce lawn areas	<input type="radio"/>	<input type="radio"/>	<input type="radio"/>	<input type="radio"/>
Pool and spa areas				
Collect, treat and re-use backwash water where possible	<input type="radio"/>	<input type="radio"/>	<input type="radio"/>	<input type="radio"/>
Collect rainwater to top up swimming pools	<input type="radio"/>	<input type="radio"/>	<input type="radio"/>	<input type="radio"/>
General and vehicle washing				
Install a recycling system that allows wash water to be reused	<input type="radio"/>	<input type="radio"/>	<input type="radio"/>	<input type="radio"/>
Retrofit existing car washes with filters, storage tanks and high pressure pumps to recycle water on-site	<input type="radio"/>	<input type="radio"/>	<input type="radio"/>	<input type="radio"/>
Install rainwater tanks to provide water for washing vehicles	<input type="radio"/>	<input type="radio"/>	<input type="radio"/>	<input type="radio"/>

Appendix E. Example Water Restrictions Poster

Level 1

Water Restrictions

On Monday, 2 March 2020, Level 1 Water Restrictions were introduced to continue the momentum of reduced water usage gained throughout the past few years while the community was tasked with severe water restrictions.

Residential Properties:

- Use of fixed hoses or sprinklers for gardening limited to 2 hours per day (4:00pm to 9:00am only);
- Use of approved micro sprays/garden watering systems limited to 2 hours per day (4:00pm to 9:00am only);
- There are no restrictions on the use of hand held hoses for gardens;
- Filling of swimming pools and spas is permitted;
- Washing hard surfaces permitted, excluding the use of hand held hoses.

Public/Commercial:

- Public gardens, sports grounds, show ground and nurseries sprinklers limited to 2 hours per day, between 5:30 pm and 7:30 am Daylight Saving Time; and between 4:30 pm and 6:30 am Eastern Standard Time;
- Market garden sprinklers limited to 6 hours per day;
- There are no restrictions on washing of motor vehicles, filling of fountains, auto flush toilets/urinals, ready mix concrete, stock troughs or water cartage.

Further information can be found at www.tenterfield.com.au/services/water



Free Stock water is still available from the Apex Park Bore



LEVEL 4

WATER RESTRICTIONS

Tooloom Creek is now at 38% capacity. Council has now enacted the Drought Management Plan and issued the town of Urbenville with Level 4 water restrictions.

Level 4 restrictions are in place from
Friday, 10 January 2020.

Restrictions on Domestic or Residential properties

NO use of fixed hoses or sprinklers for gardening;
NO washing of cars or cleaning hard surfaces;
NO filling or topping up of swimming pools and spas

Restricted use of approved micro sprays / garden watering systems to 1 hour a day, (between 6:30 pm and 7:30 pm daily Daylight Saving Time; 4:30 pm and 5:30 pm Eastern Standard Time)

Restricted use of hand held hoses to 1 hour a day, (between 6:30 pm and 7:30 pm daily Daylight Saving Time; and 4:30 pm—5:30 pm Eastern Standard Time)

Restrictions on Commercial properties

Public gardens, sporting grounds, show grounds can use hand held hoses for 1 hour (6:30 pm - 7:30 pm daily Daylight Saving Time; 4:30 pm - 5:30 pm Eastern Standard Time)

Nurseries can use hand held hoses between for 2 hours (between 6:30 pm and 6:30 am daily)

Market Gardens can use sprinklers for 2 hours (between 6:30 pm and 6:30 am daily)

Water carters require Council Approval.

The washing of motor cars, operation of fountains and auto flush toilets/urinals is BANNED.

WATER — *Let's make it last*

Full information on water restrictions can be found on Council's website www.tenterfield.nsw.gov.au, or calling **02 6736 6000**.

Appendix F. Tenterfield Water Supply and Restriction Levels

Water Restrictions	RL (AHD)	Below Spillway (m)	Current Capacity (ML)	Capacity Percent
None	878.36	0	1300.4	100%
	878.31	0.05	1279.3	98%
	878.26	0.1	1258.2	97%
	878.21	0.15	1237.1	95%
	878.16	0.2	1216.0	94%
	878.11	0.25	1194.9	92%
	878.06	0.3	1173.8	90%
	878.00	0.36	1148.5	88%
	877.96	0.4	1131.1	87%
	877.91	0.45	1109.3	85%
	877.86	0.5	1087.5	84%
	877.81	0.55	1065.8	82%
	877.76	0.6	1044.0	80%
	877.71	0.65	1022.2	79%
	877.66	0.7	1000.4	77%
	877.60	0.76	974.3	75%
	877.56	0.8	959.8	74%
	877.50	0.86	938.2	72%
	877.46	0.9	923.7	71%
Level 1	877.41	0.95	905.6	70%
	877.36	1	887.5	68%
	877.30	1.06	865.9	67%
	877.26	1.1	851.4	65%
	877.20	1.16	829.7	64%
	877.16	1.2	815.1	63%
	877.11	1.25	796.9	61%
Level 2	877.06	1.3	778.6	60%
	877.00	1.36	756.7	58%
	876.90	1.46	720.2	55%
	876.80	1.56	683.7	53%
Level 3	876.70	1.66	651.4	50%
	876.60	1.76	619.1	48%
	876.50	1.86	586.8	45%

Water Restrictions	RL (AHD)	Below Spillway (m)	Current Capacity (ML)	Capacity Percent
	876.48	1.88	580.3	45%
	876.40	1.96	554.5	43%
	876.30	2.06	526.7	41%
Level 4	876.20	2.16	499.0	38%
	876.10	2.26	471.2	36%
	876.01	2.35	446.2	34%
	875.90	2.46	427.6	33%
	875.80	2.56	410.7	32%
	875.70	2.66	393.9	30%
	875.60	2.76	377.0	29%
	875.50	2.86	360.1	28%
	875.40	2.96	341.7	26%
	875.30	3.06	323.4	25%
	875.20	3.16	305.0	23%
	875.10	3.26	286.6	22%
	875.00	3.36	271.4	21%
	874.90	3.46	256.1	20%
	874.80	3.56	240.9	19%
	874.70	3.66	225.6	17%
	874.60	3.76	212.8	16%
Level 5	874.50	3.86	200.0	15%
	874.30	4.06	174.4	13%
	873.90	4.46	131.7	10%
	873.50	4.86	97.3	7%
	873.10	5.26	69.1	5%
	872.70	5.66	46.5	4%
	872.30	6.06	28.6	2%
	871.90	6.46	15.4	1%
	871.50	6.86	6.8	1%
	871.10	7.26	2.6	0.2%
	870.70	7.66	0.7	0.1%
Dam Empty	870.30	8.06	0	0%

Water Restrictions and Forms



Contents

Introduction	1
Water Demand Targets	1
Water Restrictions Table	1
Waterwise Checklist	4
Water Exemption Application Form	7
Water Carters Registration Form	10

Introduction

This document is a subdocument of the Tenterfield Shire Council Drought Management Plan. It contains the main information relevant to the community that they may need to call on frequently. This includes the water restrictions table and forms.

For more information about Council's actions and drought planning, response and recovery please refer to the Drought Management Plan.

Water Demand Targets

Level 1 (Low)

This restriction strategy will aim to reduce normal average daily household consumption by 10% to a target level of 280L per person per day (L/P/d).

Businesses are not being strongly targeted at this level, but are encouraged to try to reduce consumption.

Level 2 (Moderate)

The second level of restrictions will aim to reduce normal average daily household consumption by 10-20% to a level of 280-250L per person per day. An increase in the advertising campaign for a reduction in water usage will be implemented.

Businesses are encouraged to review their water consumption and use tools such as the Waterwise checklist to identify areas where they may be able to save water. This checklist is provided within this document.

Level 3 (High)

The third level of restrictions will aim to reduce normal average daily household consumption by 20-30% to a level of 250-220L per person per day.

During this stage, policing is implemented with the increased monitoring of water usage throughout the community. Households and businesses with excess consumption levels will receive warning letters informing them of the possible fines that may be incurred if consumption within the dwelling or business is not

decreased. During this stage, alternate water sources, such as the Shirley Park Bore for Tenterfield, will be investigated and plans for implementation developed.

Businesses are encouraged to try to reduce water use. They are encouraged to discuss with Council if they are having issues reducing water consumption.

Level 4 (Severe)

The fourth level of restrictions will aim to reduce normal average daily household consumption by 30-40% to a level of 220-190L per person per day.

Plans for implementing alternate water sources will be finalised.

Level 5 (Emergency)

Level five restrictions will aim to reduce normal average daily household consumption by 50% to a target level of 190-160 litres per person per day (L/P/d). During this stage all non-essential water related activities are banned. Alternative water supply plans including the carting of water to the supply system, intermittent closing of the reticulation system, etc. may be implemented.

Water Restrictions Table

Type of Consumer	Permanent water conservation	Level 1 Restrictions	Level 2 Restrictions	Level 3 Restrictions	Level 4 Restrictions	Level 5 Restrictions	
Target reduction		10% reduction	10-20% reduction	20-30% reduction	30-40% reduction	40-50% reduction	
Activation Trigger (Storage Condition)		70% Dam: 1.0m below spillway; Weir: 0.45m below weir	60% Dam: 1.3m below spillway; Weir: 0.6m below weir	50% Dam: 1.7m below spillway; Weir: 0.75m below weir	40% Dam: 2.2m below spillway; Weir: 0.9m below weir	15% Dam: 3.9m below spillway; Weir: 1.25m below weir	
DOMESTIC							
Fixed hoses / sprinklers	No unattended hoses. No watering between the hours of 9am and 4pm. Vehicles should only be washed on grassed or permeable surfaces. Washing of hard surfaces with hand held hose is not permitted at any time.	Maximum 15 minutes per day between 4:00pm and 9:00am	Maximum 15 minutes per day between 4:00pm and 9:00am	Not permitted. Bucket watering permitted.	All external use of potable water is banned. Grey water use only	All external use of potable water is banned. Grey water use only	
Micro sprays / drippers / subsurface							
Hand held hoses		Maximum 1 hour per day between 4:00pm and 9:00am. One hose per property.	Maximum ½ hour per day between 4:00pm and 9:00am. One hose per property.	Maximum 10 minutes per day between 4:00pm and 9:00am. One hose per property.			
Swimming Pools and Spas		Filling permitted – no unattended hoses	Filling of new or existing pools is banned. Topping up of pools is allowed by handheld hose 1hr/day outside of the hours of 8am and 4pm	Filling of new or existing pools is banned. Topping up of pools is allowed by handheld hose 1hr/day outside of the hours of 8am and 4pm	Filling of new or existing pools is banned. Topping up of existing pools to 300mm below skimmer box by one hand held only, 1hr/week on Wednesdays.		Filling and topping up of pools banned.
Car Washing		No restrictions – no unattended hoses	Buckets only	Buckets only	Cleaning of windows, windscreens, lights and mirrors with buckets.		Cleaning of windows, windscreens, lights and mirrors with grey water.
Washing Hard Surfaces					Banned		Banned
BUSINESS / COMMERCIAL PREMISES ETC.							
Public gardens, sports grounds & community facilities	No unattended hoses. No watering between the hours of 9am and 4pm.	As per residential restrictions. Exception: sprinkler may be used up to 2hrs/ day for essential businesses (e.g. nurseries) or where business hours dictate water use, e.g. schools	As per residential restrictions. Exception: sprinkler may be used up to 2hrs/day for essential businesses (e.g. nurseries) or where business hours dictate water use, e.g. schools	Hand held hoses allowed for 1 hour per day outside the hours of 8am and 4pm	Buckets or watering cans only	Use of town water is banned	
Nurseries				Sprinklers and hand held hoses allowed for 2hrs/day. Application for times.	Sprinklers/hand held hoses 1hr/day – application for times.	Use of town water is banned	

Type of Consumer	Permanent water conservation	Level 1 Restrictions	Level 2 Restrictions	Level 3 Restrictions	Level 4 Restrictions	Level 5 Restrictions
Bowling Greens				Hand held hoses allowed for 1 hour per day outside the hours of 8am and 4pm		Use of town water is banned
New turf / landscaping	Newly laid turf may be watered with water conserving equipment for a period of up to six (6) weeks from the installation of the turf.			Water in – then hand held hoses 1 hour per day outside hours of 8am and 4pm	Buckets or watering cans only	Use of town water is banned
Public pools		Filling permitted – no unattended hoses	Filling of pools is banned. Topping up of pools is allowed by handheld hose 1hr/day outside of the hours of 8am and 4pm	Topping up allowed	Topping up with alternative water supply permitted. Town water use not permitted.	Topping up with alternative water supply permitted. Town water use not permitted.
Washing motor vehicles ¹ – cars, taxis, food transport, commercial etc.			Buckets only on grassed areas. Exemption may be granted if proof of water efficient devices provided	Buckets only on grassed areas. Exemption may be granted if proof of water efficient devices provided	Buckets only on grassed areas. Exemption may be granted if proof of water efficient devices provided	Use of town water is banned
Building construction	No unattended hoses between the hours of 9am and 4pm			No restriction on essential business use	Restricted to essential business use.	Use of town water is banned
Paved public areas; where food is prepared or consumed or for health reasons		No restrictions – no unattended hoses	No restrictions – no unattended hoses	Hand held hoses 1hr/day – eating / preparation areas for health reasons only	Buckets or watering cans – eating / preparation areas for health reasons only	Buckets or watering cans – eating / preparation areas for health reasons only
Water cartage – potable supply				Filling of domestic tanks only – private carriers must be registered.	Council approved private water carters only	Use of town water is banned
Auto flush urinals / public toilets				On timers – banned On Demand - ok	On timers – banned On Demand - ok	On timers – banned On Demand – ok Public toilets closed

Type of Consumer	Permanent water conservation	Level 1 Restrictions	Level 2 Restrictions	Level 3 Restrictions	Level 4 Restrictions	Level 5 Restrictions
INDUSTRIAL						
Ready mix concrete & other industrial operations	No unattended hoses between the hours of 9am and 4pm	No restriction on water usage for essential business activities	No restriction on water usage for essential business activities	Restricted to 8 hours / day operations	Council Approved	Use of town water is banned
RURAL						
Stock watering	No restriction	No restriction	Council Approved	Council Approved	Council Approved	Use of town water is banned
¹ Emergency vehicles are exempt, but are encouraged to be water wise						

Waterwise Checklist

The Waterwise checklist is a two page document – page 1 focuses on identifying where immediate water savings can be made and page 2 focuses on identifying how additional water savings can be made in the future.



Be Waterwise

Reduce the Use

WATER CHECKLIST: Review your water conservation practices and plan ahead

Water conservation tips for your workplace or community facility	We do this now	We will review	N/A	Need to follow-up
ACTIONS – What can I do now?				
General review				
Check water meters are working properly and monitor use	<input type="radio"/>	<input type="radio"/>	<input type="radio"/>	<input type="radio"/>
Install signage to encourage water conservation	<input type="radio"/>	<input type="radio"/>	<input type="radio"/>	<input type="radio"/>
Ensure fire water hoses are not used for general activities	<input type="radio"/>	<input type="radio"/>	<input type="radio"/>	<input type="radio"/>
Amenity areas				
Check toilet cisterns for leaks and repair as required	<input type="radio"/>	<input type="radio"/>	<input type="radio"/>	<input type="radio"/>
Use cistern weights to reduce volume in single flush toilets	<input type="radio"/>	<input type="radio"/>	<input type="radio"/>	<input type="radio"/>
Adjust timings and volumes of automatic flush urinals	<input type="radio"/>	<input type="radio"/>	<input type="radio"/>	<input type="radio"/>
Install tap aerators or tap flow control valves	<input type="radio"/>	<input type="radio"/>	<input type="radio"/>	<input type="radio"/>
Install water efficient showerheads or shower control valves	<input type="radio"/>	<input type="radio"/>	<input type="radio"/>	<input type="radio"/>
Heating and cooling systems				
Turn off air conditioner cooling systems when not required	<input type="radio"/>	<input type="radio"/>	<input type="radio"/>	<input type="radio"/>
Check blowdown/bleed-off control on boilers and cooling towers	<input type="radio"/>	<input type="radio"/>	<input type="radio"/>	<input type="radio"/>
Increase concentration cycles for air conditioning cooling towers	<input type="radio"/>	<input type="radio"/>	<input type="radio"/>	<input type="radio"/>
Check the seal and float valve unit for wear. Review settings.	<input type="radio"/>	<input type="radio"/>	<input type="radio"/>	<input type="radio"/>
Check the cooling system pump for leaks	<input type="radio"/>	<input type="radio"/>	<input type="radio"/>	<input type="radio"/>
Outdoor water use				
Install signage to increase awareness of water restrictions	<input type="radio"/>	<input type="radio"/>	<input type="radio"/>	<input type="radio"/>
Inspect, repair or replace any leaking pipes and outdoor taps	<input type="radio"/>	<input type="radio"/>	<input type="radio"/>	<input type="radio"/>
Sweep or use garden blowers on paved areas instead of hosing (<i>unless required to meet occupational health and safety standards</i>)	<input type="radio"/>	<input type="radio"/>	<input type="radio"/>	<input type="radio"/>
Attach trigger nozzles to all hoses (<i>permissible uses only</i>)	<input type="radio"/>	<input type="radio"/>	<input type="radio"/>	<input type="radio"/>
Use high pressure cleaning units in place of hoses (<i>permissible uses only</i>)	<input type="radio"/>	<input type="radio"/>	<input type="radio"/>	<input type="radio"/>
Review options to meet plant water needs when maintaining gardens	<input type="radio"/>	<input type="radio"/>	<input type="radio"/>	<input type="radio"/>
Use mulch around ground covers, trees and shrubs	<input type="radio"/>	<input type="radio"/>	<input type="radio"/>	<input type="radio"/>
Adjust times for automatic irrigation equipment (e.g. sporting fields). Turn off timers when water is not required	<input type="radio"/>	<input type="radio"/>	<input type="radio"/>	<input type="radio"/>
Ensure hard surfaces are not being watered	<input type="radio"/>	<input type="radio"/>	<input type="radio"/>	<input type="radio"/>
Pool and spa areas				
Use a pool cover to reduce water loss due to evaporation	<input type="radio"/>	<input type="radio"/>	<input type="radio"/>	<input type="radio"/>
Check for and repair any leaks	<input type="radio"/>	<input type="radio"/>	<input type="radio"/>	<input type="radio"/>
Check the filter backwash schedule and adjust if possible	<input type="radio"/>	<input type="radio"/>	<input type="radio"/>	<input type="radio"/>
Keep heated pools to a minimum temp to reduce evaporation	<input type="radio"/>	<input type="radio"/>	<input type="radio"/>	<input type="radio"/>
Vehicle washing				
Limit the number of spray nozzles, their flow rate and pressure	<input type="radio"/>	<input type="radio"/>	<input type="radio"/>	<input type="radio"/>
Place timers and shut-off valves on vehicle washers	<input type="radio"/>	<input type="radio"/>	<input type="radio"/>	<input type="radio"/>
Use rainwater to wash vehicles where required	<input type="radio"/>	<input type="radio"/>	<input type="radio"/>	<input type="radio"/>



Be Waterwise

Reduce the Use

Water conservation tips for your workplace or community facility	We do this now	We report to staff	N/A	Listed in asset register
How can I plan for the future?				
General review				
Schedule daily or weekly water meter reads and share information with staff and management to monitor trends	<input type="radio"/>	<input type="radio"/>	<input type="radio"/>	<input type="radio"/>
Maintain signage to encourage water conservation (e.g. <i>turn off the tap</i>)	<input type="radio"/>	<input type="radio"/>	<input type="radio"/>	<input type="radio"/>
Schedule fire water hose testing dates	<input type="radio"/>	<input type="radio"/>	<input type="radio"/>	<input type="radio"/>
Develop a roster for checking leaks and undertaking repairs	<input type="radio"/>	<input type="radio"/>	<input type="radio"/>	<input type="radio"/>
Gauge interest in staff being “water champions” to assist water monitoring and sharing of information	<input type="radio"/>	<input type="radio"/>	<input type="radio"/>	<input type="radio"/>
Amenity areas				
Install sensor activated taps where appropriate	<input type="radio"/>	<input type="radio"/>	<input type="radio"/>	<input type="radio"/>
Retrofit toilet cisterns with more water efficient models	<input type="radio"/>	<input type="radio"/>	<input type="radio"/>	<input type="radio"/>
Review capacity to collect rainwater for the purpose of toilet flushing	<input type="radio"/>	<input type="radio"/>	<input type="radio"/>	<input type="radio"/>
Replace automatic flush urinals and low flush valve operated urinals, waterless urinals or manual operated urinals	<input type="radio"/>	<input type="radio"/>	<input type="radio"/>	<input type="radio"/>
Schedule appliance replacement e.g. dishwashers and washing machines and identify best products using the Water Efficiency Labelling Scheme (WELS)	<input type="radio"/>	<input type="radio"/>	<input type="radio"/>	<input type="radio"/>
Heating and cooling systems				
Investigate recycling water flow to cooling tower or replacing with air-cooled equipment to eliminate ‘once through’ cooling of equipment processes	<input type="radio"/>	<input type="radio"/>	<input type="radio"/>	<input type="radio"/>
Insulate water pipes to reduce water use while waiting for it to heat up	<input type="radio"/>	<input type="radio"/>	<input type="radio"/>	<input type="radio"/>
Schedule regular inspections of cooling system pumps and seals	<input type="radio"/>	<input type="radio"/>	<input type="radio"/>	<input type="radio"/>
Outdoor water use				
Install automatic shut-off valves on manual hoses	<input type="radio"/>	<input type="radio"/>	<input type="radio"/>	<input type="radio"/>
Collect rainwater and water from cooling tower bleed-off for re-use on landscaping	<input type="radio"/>	<input type="radio"/>	<input type="radio"/>	<input type="radio"/>
Review garden design and layout – group plants with similar water needs, and reduce lawn areas	<input type="radio"/>	<input type="radio"/>	<input type="radio"/>	<input type="radio"/>
Pool and spa areas				
Collect, treat and re-use backwash water where possible	<input type="radio"/>	<input type="radio"/>	<input type="radio"/>	<input type="radio"/>
Collect rainwater to top up swimming pools	<input type="radio"/>	<input type="radio"/>	<input type="radio"/>	<input type="radio"/>
General and vehicle washing				
Install a recycling system that allows wash water to be reused	<input type="radio"/>	<input type="radio"/>	<input type="radio"/>	<input type="radio"/>
Retrofit existing car washes with filters, storage tanks and high pressure pumps to recycle water on-site	<input type="radio"/>	<input type="radio"/>	<input type="radio"/>	<input type="radio"/>
Install rainwater tanks to provide water for washing vehicles	<input type="radio"/>	<input type="radio"/>	<input type="radio"/>	<input type="radio"/>

Water Exemption Application Form

The form below is to be used to apply for a water use exemption.

Forms can be emailed to council@tenterfield.nsw.gov.au, posted to PO Box 214, Tenterfield, NSW, 2372, or returned in person to Council's Administration Centre.

Please note that watering during the hottest part of the day (middle of the day) will *NOT* be permitted under any circumstance.

Exemptions will expire when a certain water restriction level is reached, which will be outlined on your permit.

Submitting a permit does not guarantee approval. Permits can take up to 10 working days for approval.



Water Restriction Exemption Request Form

Please note: watering of gardens will *NOT* be permitted under any circumstances in the middle of the day.

Customer/ Business		
Property address		
Contact phone numbers	B:	M:
Email address		

Category of restriction to which the permit request applies (tick ONE box only)	
<input type="checkbox"/> Private Gardens <input type="checkbox"/> Public Gardens <input type="checkbox"/> Ponds and Lakes <input type="checkbox"/> Fountains <input type="checkbox"/> Cleaning Windows/ Building Roofs <input type="checkbox"/> Farm Dams <input type="checkbox"/> Swimming Pools <input type="checkbox"/> Cleaning Paved Areas	<input type="checkbox"/> Construction Activities <input type="checkbox"/> Sports Grounds / Recreation Areas <input type="checkbox"/> Retail / Wholesale / Market Gardens <input type="checkbox"/> Nursery <input type="checkbox"/> Vehicles, Boats or Aircraft <input type="checkbox"/> Other (please list)

Exemption request details		
Time:	Days:	Dates:

Reason of which exemption should be granted	
<input type="checkbox"/> Adverse financial impact <input type="checkbox"/> Request results in less water being used <input type="checkbox"/> Special needs	<input type="checkbox"/> Physical damage to a building or structure <input type="checkbox"/> Public health or safety <input type="checkbox"/> Filling swimming pool or spa

Please indicate the expected volumes of water required and details of how water will be used

Please indicate the measures in place to reduce the amount of water that will be used

Applicant Declaration

I/we agree to:

- Authorise Tenterfield Shire Council (Council) to publically disclose any relevant details of the permit;
- Adhere to ALL the specific requirements contained within the permit;
- Provide appropriate access to enable Council to assess adherence to the permit conditions;
- Complete all sections of this form;
- Acknowledge that the exemption, if approved, is not transferable to any other party or location and is the responsibility of the permit holder;
- Ensure that every effort will be made to conserve water at all times;
- The permit is relevant only to the current water restriction level. Upon increase of water restrictions, this permit will be void unless otherwise stated within the approval;
- Any violation of the terms of the permit will result in the immediate disqualification of the permit.

Signature of Applicant	
Date	

Forms can be emailed to council@tenterfield.nsw.gov.au, posted to PO Box 214, Tenterfield, NSW, 2372, or returned in person to Council's Administration Centre.

Office use only

Date form received	
--------------------	--

Exemption Request: Approved Denied

Reason for decision	
Permit Number	
Date of commencement	
Date of expiry	
Water restriction level permit expires at	
Name of Authorising Officer	
Signature of authorising officer	
Date	

Water Carters Registration Form

During times of drought, any water carters taking potable water from Council's standpipes need to be registered.

Once approved, access to Council's standpipes will be granted, either in Tenterfield, Urbenville or both.

Water carters are expected to keep records of date, volume of water taken, property that water is being supplied to and intended use. Council can ask to see these records at any time. Once Level 3 water restrictions are reached, water can only be taken for filling of domestic tanks.

Water taken from Council's dispensers can only be supplied to properties within the Tenterfield Shire Council Local Government Boundary, unless specific approval is granted in writing from Council.



Water Carter Registration Form

Business name:		
ABN		
Proprietor/s		
Business/office address		
Mailing address (if different from above)		
Contact phone numbers	B:	M:
Email address		
Is your business registered with the Australian Charities and Not-for-profits Commission?		
<input type="checkbox"/> Yes <input type="checkbox"/> No		

Legislative Requirements		
<i>Requirements</i>	<i>Documents Required</i>	<i>Document Attached</i>
Quality Assurance Program has been developed and submitted to NSW Health to meet the requirements of NSW Water Carters Guidelines	Yes	
The vehicle(s) are fitted with a backflow prevention device or registered air gap that complies with the Plumbing Code of Australia	Yes	
The device or air gap has been tested in the past 12 months by a qualified person	Yes	
The vehicle has public liability insurance for not less than \$20 million dollars indemnifying Tenterfield Shire Council against any claims that may arise from the operation of the water carter business	Yes	

Vehicle(s) Information	
Number of vehicles used for carting	
Registration number of above vehicles	
Tanker dimensions	
Tanker Volume	
Location of where water is drawn	
<input type="checkbox"/> Tenterfield <input type="checkbox"/> Urbenville	

Applicant Declaration

I/we agree to:

- Authorise Tenterfield Shire Council (Council) to publically disclose any relevant details of the permit;
- Complete all sections of this form;
- Ensure that every effort will be made to conserve water at all times;
- Confirm that records will be kept of date, volumes taken and delivery address. Council may request this data at any time;
- Confirm that water taken from Councils' dispensers will be delivered to properties within the Tenterfield Shire Local Government Boundary only;
- Confirm that water taken from Councils' dispensers will be supplied for domestic use only (no filling of dams);
- When the dispenser key is issued, confirm that it will be used for the vehicles registered above only. The key cannot be loaned to other vehicles or companies. Failure to comply with this will result in the key being returned and removal from the Council's registered water carter list;

Signature of Applicant	
Date	

Forms can be emailed to council@tenterfield.nsw.gov.au, posted to PO Box 214, Tenterfield, NSW, 2372, or returned in person to Council's Administration Centre.

Office use only

Date form received	
--------------------	--

Registration Request: Approved Denied

Reason for decision	
Registration Number	
Date of commencement	
Date of expiry	
Name of Authorising Officer	
Signature of authorising officer	
Date	